



**Dell XC730xd-12C Web-Scale  
Hyperconverged Appliance  
Owner's Manual**



# Notes, cautions, and warnings

-  **NOTE:** A NOTE indicates important information that helps you make better use of your computer.
-  **CAUTION:** A CAUTION indicates either potential damage to hardware or loss of data and tells you how to avoid the problem.
-  **WARNING:** A WARNING indicates a potential for property damage, personal injury, or death.

**Copyright © 2016 Dell Inc. All rights reserved.** This product is protected by U.S. and international copyright and intellectual property laws. Dell™ and the Dell logo are trademarks of Dell Inc. in the United States and/or other jurisdictions. All other marks and names mentioned herein may be trademarks of their respective companies.

2016 - 05

Rev. A03

# Contents

<b>1 About your system.....</b>	<b>8</b>
Supported configuration.....	8
Front-panel features and indicators.....	8
Diagnostic indicators.....	10
Hard drive indicator codes.....	11
iDRAC Direct LED indicator codes.....	12
Back-panel features and indicators.....	14
NIC indicator codes.....	16
Power indicator codes.....	16
Documentation references.....	19
<b>2 Performing initial system configuration .....</b>	<b>20</b>
Setting up your system.....	20
Methods of setting up and configuring the iDRAC IP address .....	20
Logging in to iDRAC.....	20
Installing the operating system.....	21
Remote management.....	21
Downloading and installing drivers and firmware.....	21
<b>3 Pre-operating system management applications.....</b>	<b>22</b>
Navigation keys.....	22
About System Setup.....	23
Entering System Setup.....	23
System Setup Main Menu.....	24
Editing system BIOS screen settings.....	24
Editing system information.....	25
Editing memory settings.....	25
Editing processor settings.....	26
Editing SATA Settings.....	28
Editing boot settings screen.....	31
Editing network settings.....	31
Editing integrated devices details.....	32
Editing serial communication settings.....	33
Editing system profile .....	34
Editing system security.....	36
Editing miscellaneous settings.....	38
About Boot Manager.....	39
Entering Boot Manager .....	39

Boot Manager main menu.....	39
Changing the boot order.....	39
Choosing the system boot mode.....	40
Assigning a system and setup password.....	40
Deleting or changing an existing system password and setup password.....	41

## **4 Installing and removing system components.....42**

Safety instructions.....	42
Before working inside your system.....	42
After working inside your system.....	42
Recommended tools.....	43
Front bezel.....	43
Removing the front bezel.....	43
Installing the front bezel.....	44
Removing the system cover.....	44
Installing the system cover.....	45
Inside the system.....	46
Cooling shroud.....	47
Removing the cooling shroud.....	47
Installing the cooling shroud.....	48
Cooling fans.....	48
Removing a cooling fan.....	48
Installing a cooling fan.....	49
Cooling-fan assembly.....	50
Removing the cooling-fan assembly.....	50
Installing the cooling-fan assembly.....	51
System memory.....	51
General memory module installation guidelines.....	53
Sample memory configurations.....	53
Removing memory modules.....	53
Installing memory modules.....	55
SATADOM.....	56
Important information about SATADOM.....	57
Removing the SATADOM.....	57
Installing the SATADOM.....	58
Heat sinks and processors.....	59
Removing a processor.....	59
Installing a processor.....	64
PCIe card holder.....	66
Removing the PCIe card holder.....	66
Installing the PCIe card holder.....	67
Opening and closing the PCIe card holder latch.....	67

Cable retention bracket.....	68
Removing the cable retention bracket.....	68
Installing the cable retention bracket.....	69
Integrated storage controller card.....	70
Removing the integrated storage controller card.....	70
Installing the integrated storage controller card.....	71
Expansion cards and expansion-card risers.....	72
Expansion card installation guidelines.....	72
Removing an expansion card from expansion-card riser 2 or 3.....	73
Installing an expansion card into the expansion-card riser 2 or 3.....	74
Removing expansion-card risers.....	75
Installing expansion-card risers.....	80
Internal dual SD module.....	80
Removing an internal SD card.....	80
Installing an internal SD card.....	81
Removing the internal dual SD module .....	81
Installing the internal dual SD module .....	83
Network daughter card.....	83
Removing the network daughter card .....	83
Installing the network daughter card.....	85
System battery.....	85
Replacing the system battery.....	85
Power supply units.....	86
Hot Spare feature.....	87
Removing the power supply unit blank.....	87
Installing the power supply unit blank.....	88
Removing an AC power supply unit.....	88
Installing an AC power supply unit.....	89
Wiring instructions for a DC power supply unit.....	90
Removing a DC power supply unit.....	91
Installing a DC power supply unit.....	92
System board.....	92
Removing the system board.....	92
Installing the system board.....	94
Trusted Platform Module.....	97
Installing the Trusted Platform Module .....	97
Re-enabling the TPM for BitLocker users.....	98
Re-enabling the TPM for TXT users.....	98
Hard drives.....	99
Removing a 3.5-inch hard-drive blank.....	99
Installing a 3.5-inch hard-drive blank.....	100
Removing a hot-swap hard drive.....	100

Installing a hot-swap hard drive.....	101
Removing a hard drive from a hard-drive carrier.....	102
Installing a hard drive into a hard-drive carrier.....	102
Hard-drive backplane.....	103
Removing the hard-drive backplane.....	103
Installing the hard-drive backplane.....	104
Removing the optional hard-drive backplane (back).....	105
Removing the control panel.....	105
Installing the control panel.....	106
Removing the I/O panel.....	107
Installing the I/O panel.....	108
Removing the hard-drive backplane from the hard-drive tray.....	109
Installing the hard-drive backplane in the hard-drive tray.....	110

## **5 Troubleshooting your system..... 111**

Safety first—for you and your system.....	111
Troubleshooting system startup failure.....	111
Troubleshooting external connections.....	111
Troubleshooting the video subsystem.....	111
Troubleshooting a USB device.....	111
Troubleshooting iDRAC Direct (USB XML configuration).....	112
Troubleshooting iDRAC Direct (laptop connection).....	113
Troubleshooting a serial I/O device.....	113
Troubleshooting a NIC.....	113
Troubleshooting a wet system.....	114
Troubleshooting a damaged system.....	115
Troubleshooting the system battery.....	115
Troubleshooting power supply units.....	116
Power source problems.....	116
PSU problems.....	116
Troubleshooting cooling problems.....	117
Troubleshooting cooling fans.....	117
Troubleshooting system memory.....	118
Troubleshooting an SD card.....	119
Troubleshooting a hard drive.....	119
Troubleshooting a storage controller.....	120
Troubleshooting expansion cards.....	121
Troubleshooting processors.....	121
System messages.....	122
Warning messages.....	122
Diagnostic messages.....	122
Alert messages.....	122

<b>6 Using system diagnostics.....</b>	<b>123</b>
Dell Embedded System Diagnostics.....	123
When to use the Embedded System Diagnostics.....	123
Running the Embedded System Diagnostics from Boot Manager.....	123
Running the Embedded System Diagnostics from the Dell Lifecycle Controller.....	123
System diagnostic controls.....	124
<b>7 Jumpers and connectors.....</b>	<b>125</b>
System board jumper settings.....	125
System board connectors.....	126
Disabling a forgotten password.....	128
<b>8 Getting help.....</b>	<b>129</b>
Contacting Dell.....	129
Dell SupportAssist.....	129
Locating Service Tag of your system.....	129
Quick Resource Locator.....	130

## About your system

The Dell XC730xd-12C system is web-scale converged appliance based on the Dell PowerEdge R730xd that supports one Intel Xeon E5-2620 v3 processor, and 12 hard drives or solid-state drives (SSDs).

 **NOTE:** The systems support only internal drives 32 GB RAM.

 **NOTE:** The maximum supported capacity is 32 TB (8x4 TB).

## Supported configuration

**Table 1. Supported configuration**

Systems	Configurations
Twelve hard-drive systems	Up to twelve 3.5-inch hard drives.



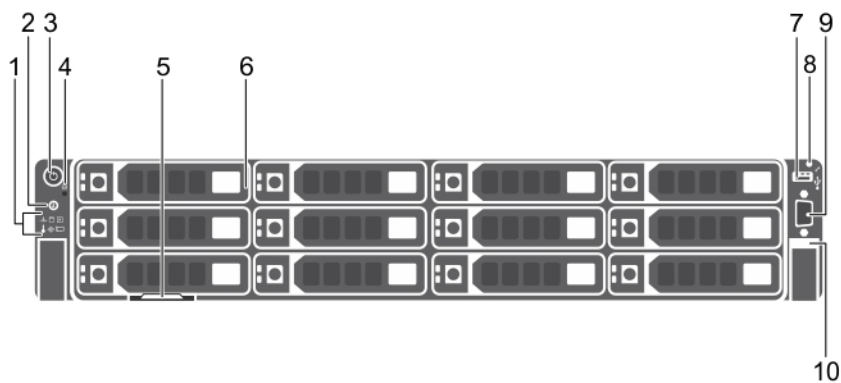

## Front-panel features and indicators

This topic describes about the front-panel features and indicators.



**Figure 1. 3.5-inch hard drive chassis**

**Table 2. Front-panel features and indicators**

Item	Indicator, Button, or Connector	Icon	Description
1	Diagnostic indicators		The diagnostic indicators light up to display error status. For more information, see <a href="#">Diagnostic indicators</a> .
2	System identification button		You can use the identification buttons on the front- and back panels to locate a particular system within a rack. When one of these buttons is pressed, the system status indicator on the back flashes until one of the buttons is pressed again. Press to toggle the system ID on and off. If the system stops functioning during POST, press and hold the system ID button for more than five seconds to go the BIOS progress mode. To reset iDRAC (if not disabled by entering iDRAC setup mode by pressing ) press and hold the button for more than 15 seconds.
3	Power-on indicator, Power button		The power-on indicator glows when the system power is on. The Power button controls the power supply unit output to the system.   <b>NOTE:</b> On the Advanced Configuration and Power Interface (ACPI)-compliant operating systems (OSs), turning off the system by using the power button causes the system to perform a graceful shutdown before power to the system is disconnected.
4	NMI button		Use the Non-Maskable Interrupt (NMI) button to troubleshoot software and device driver errors while running certain OSs. Press the NMI button by using the end of a paper clip.  Use the NMI button only if directed by qualified support personnel or by the OS's documentation.
5	Information tag		A slide-out label panel, which allows you to record system information such as Service Tag, NIC, MAC address.
6	Hard drives		Up to twelve 3.5-inch hot-swappable hard drives.
7	USB management port/ iDRAC Direct		Allows you to connect USB devices to the system or provides access to the iDRAC Direct features. For more information, see the <i>Integrated Dell Remote Access Controller User's Guide</i> at <a href="http://Dell.com/idracmanuals">Dell.com/idracmanuals</a> . The USB management port is USB 2.0-compliant.
8	iDRAC Direct LED indicator		The indicator glows up to display error status.

Item	Indicator, Button, or Connector	Icon	Description
9	Video connector		Enables you to connect a display to the system.





## Diagnostic indicators



The diagnostic indicators on the system front-panel display error status during system startup.

 **NOTE:** The diagnostic indicators are not present if the system is equipped with an LCD display.

 **NOTE:** No diagnostic indicators are lit when the system is switched off. To start the system, plug it in to a working power source and press the power button.

**Table 3. Diagnostic indicators**

Icon	Description	Condition	Corrective action
	Health indicator	If the system is turned on, and in good health, glows solid blue.  Blinks amber if the system is turned on or in standby, and if any error exists (for example, a failed fan or hard drive).	None required.  See the system event log or system messages for the specific issue. For more information about the error messages, see the <i>Dell Event and Error Messages Reference Guide</i> at <a href="http://Dell.com/openmanagemanuals">Dell.com/openmanagemanuals</a> > <b>OpenManage software</b> .  Invalid memory configurations can cause the system to stop functioning at startup without any video output. See <a href="#">Getting help</a> .
	Hard drive indicator	Blinks amber if a hard drive experiences an error.	See the system event log to determine the Hard drive that has an error. Run the appropriate online diagnostics test. Restart system and run embedded diagnostics (ePSA).
	Electrical indicator	Blinks amber if the system experiences an electrical error (for example, voltage out of range, or a failed power supply unit or voltage regulator).	See the system event log or system messages for the specific issue. If it is because of a problem with the power supply unit (PSU), check the LED on the PSU. Reseat the PSU by removing and reinstalling it. If the issue persists, see <a href="#">Getting help</a> .
	Temperature indicator	Blinks amber if the system experiences a thermal error (for example, a temperature out of range or fan failure).	Ensure that none of the following conditions exist: <ul style="list-style-type: none"> <li>• A cooling fan is removed or has failed.</li> <li>• System cover, cooling shroud, EMI filler panel, memory-module</li> </ul>

Icon	Description	Condition	Corrective action
			<p>blank, or back-filler bracket is removed.</p> <ul style="list-style-type: none"> <li>Ambient temperature is too high.</li> <li>External airflow is obstructed.</li> </ul> <p>See <a href="#">Getting help</a>.</p>
	Memory indicator	Blinks amber if a memory error occurs.	See the system event log or system messages for the location of the failed memory. Reinstall the memory device. If the issue persists, see <a href="#">Getting help</a> .
	PCIe indicator	Blinks amber if a PCIe card experiences an error.	Restart the system. Update any required drivers for the PCIe card. Reinstall the card. If the issue persists, see <a href="#">Getting help</a> .
	<b>NOTE:</b> For more information about supported PCIe cards, see <a href="#">Expansion card installation guidelines</a> .		

## Hard drive indicator codes

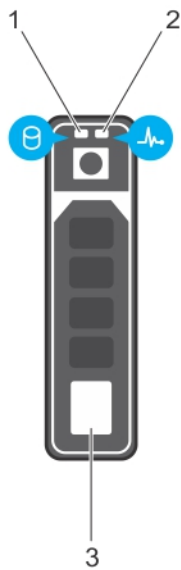

**Figure 2. Hard drive indicators**

- |                                  |                                |
|----------------------------------|--------------------------------|
| 1. Hard drive activity indicator | 2. Hard drive status indicator |
| 3. Hard drive                    |                                |

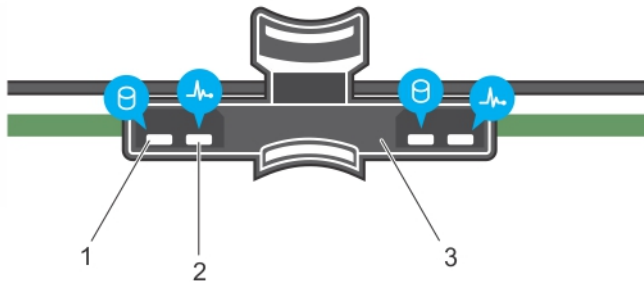

**Figure 3. HDD indicators on the hard-drive tray backplane**

1. Hard drive activity indicator
2. Hard drive status indicator
3. Hard drive backplane on hard-drive tray

**NOTE:** If the hard drive is in Advanced Host Controller Interface (AHCI) mode, the status indicator (on the right side) does not function and remains off.

**Table 4. Drive-status indicator pattern**

Drive-status indicator pattern	Condition
Blinks green two times per second	Identifying drive or preparing for removal. HDD or SSD location is enabled for one or more HDDs or SSDs is in the failed state on the Nutanix Web GUI.
Off	Drive ready for insertion or removal. <b>NOTE:</b> The drive status indicator remains off until all hard drives are initialized after the system is turned on. Drives are not ready for insertion or removal during this time.
Blinks green, amber, and turns off	Predicted drive failure
Blinks amber four times per second	Drive failed
Blinks green slowly	Drive rebuilding
Steady green	Drive online
Blinks green three seconds, amber three seconds, and turns off six seconds	Rebuild aborted

## iDRAC Direct LED indicator codes

This topic describes about the iDRAC Direct LED indicator codes.

**NOTE:** The iDRAC Direct LED indicator does not glow for the USB mode.

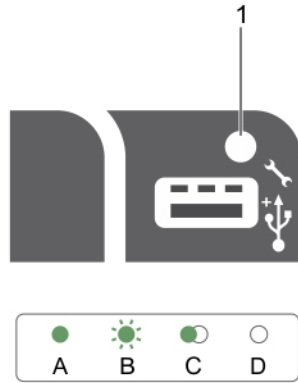

**Figure 4. iDRAC Direct LED indicator**

1. iDRAC Direct status indicator

The following table displays iDRAC Direct activity when configuring iDRAC Direct by using the management port (USB XML Import).

**Table 5. iDRAC Direct by using the management port (USB XML Import).**

Convention	iDRAC Direct LED indicator pattern	Condition
A	Green	Glows green for a minimum of two seconds at the beginning and end of a file transfer.
B	Flashing green	Indicates file transfer or any operation tasks.
C	Green and turns off	Indicates that the file transfer is complete.
D	Not lit	Indicates that the USB is ready to be removed or that a task is complete.

The following table describes about iDRAC Direct activity when configuring iDRAC Direct using your laptop and cable (Laptop connect).

**Table 6.**

iDRAC Direct LED indicator pattern	Condition
Solid green for two seconds	Indicates that the laptop is connected.
Flashing green (on for two seconds and off for two seconds)	Indicates that the laptop connected is recognized.
Turns off	Indicates that the laptop is unplugged.

## Back-panel features and indicators

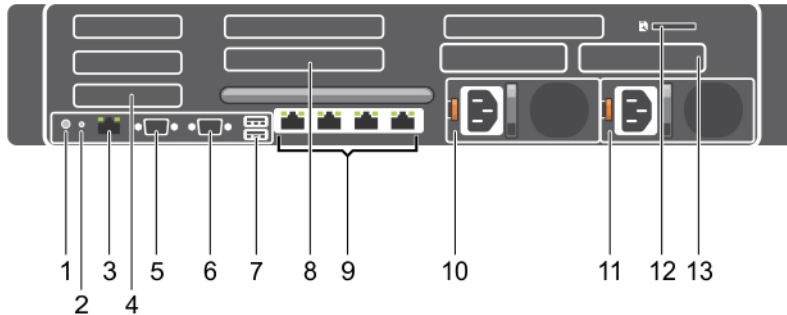









Figure 5. Back-panel features and indicators

Table 7. Back-panel features and indicators

Item	Indicator, button, or connector	Icon	Description
1	System identification button		<p>You can use the identification buttons on the front to locate a particular system within a rack. When one of these buttons is pressed, the system status indicator on the back flashes until one of the buttons is pressed again.</p> <p>Press to toggle the system ID on and off. If the system stops responding during POST, press and hold the system ID button for more than five seconds to enter the BIOS progress mode.</p> <p>To reset iDRAC (if not disabled in F2 iDRAC setup) press and hold the button for more than 15 seconds.</p>
2	System identification connector		Connects the optional system status indicator assembly through the optional cable management arm.
3	iDRAC8 Enterprise port		Dedicated management port for iDRAC8.
4	Half-height PCIe expansion-card slot (3)		Allows you to connect up to three half-height PCI Express expansion cards.
5	Serial connector		Allows you to connect a serial device to the system.
6	Video connector		Allows you to connect a VGA display to the system.

Item	Indicator, button, or connector	Icon	Description
7	USB connector (2)		Allows you to connect USB devices to the system. The ports are USB 3.0-compliant.
8	Full-height PCIe expansion-card slot (3)		Allows you to connect up to three full-height PCI Express expansion cards. These are reserved for Dell PERC H310 and LSI 9207-8i.
9	Ethernet connector (4)		Four integrated 10/100/1000 Mbps NIC connectors or Four integrated connectors that include: <ul style="list-style-type: none"> <li>• Two 10/100/1000 Mbps NIC connectors</li> <li>• Two 100 Mbps/1 Gbps/10 Gbps SFP +/10 GbE T connectors</li> </ul>
10	Power supply unit (PSU1)		<b>AC</b> 495 W, 750 W, or 1100 W
11	Power supply unit (PSU2)		<b>DC</b> 495 W, 750 W, or 1100 W
12	vFlash media card slot		Allows you to insert a vFlash media card.
13	Two HDD blanks		Up to two hot-swappable 2.5-inch hard drives.

## NIC indicator codes

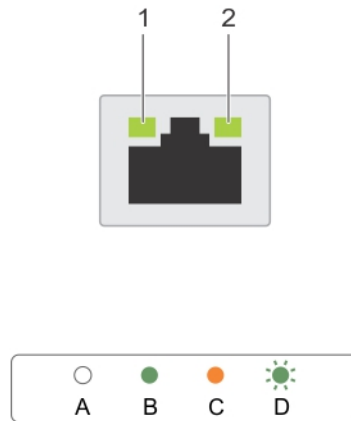

**Figure 6. NIC indicators**

1. link indicator
2. activity indicator

**Table 8. NIC indicators**

Convention	Indicator	Indicator code
A	Link and activity indicators are off	The NIC (network interface card) is not connected to the network.
B	Link indicator is green	The NIC is connected to a valid network at its maximum port speed (1 Gbps or 10 Gbps).
C	Link indicator is amber	The NIC is connected to a valid network at less than its maximum port speed.
D	Activity indicator is blinking green	Network data is being sent or received.

## Power indicator codes

Each AC power supply unit (PSU) has an illuminated translucent handle and each DC power supply unit (when available) has an LED that serves as an indicator to show whether power is present or a power fault has occurred.



**Figure 7. AC power supply unit status indicator**

1. AC power supply unit status indicator or handle

**Table 9. AC Power indicator**

Convention	Power indicator pattern	Condition
A	Green	The handle indicator glows green indicating that a valid power source is connected to the power supply unit and that the power supply unit is operational.
B	Flashing green	When updating the firmware of the power supply unit, the power supply unit handle flashes green.
C	Flashing green and turns off	When hot-adding a power supply unit (PSU), the power supply unit handle flashes green five times at 4 Hz rate and turns off. This indicates that the power supply unit is mismatched with the other power supply unit (in terms of efficiency, feature set, health status, and supported voltage). Replace the power supply unit that has the flashing indicator with a power supply unit that matches the capacity of the other installed power supply unit.
		 <b>NOTE:</b> For AC power supplies, use only PSUs with the Extended Power Performance (EPP) label on the back. Mixing PSUs from previous generations of servers can result in a PSU mismatch condition or failure to turn on.
D	Flashing amber	Indicates a problem with the power supply unit.



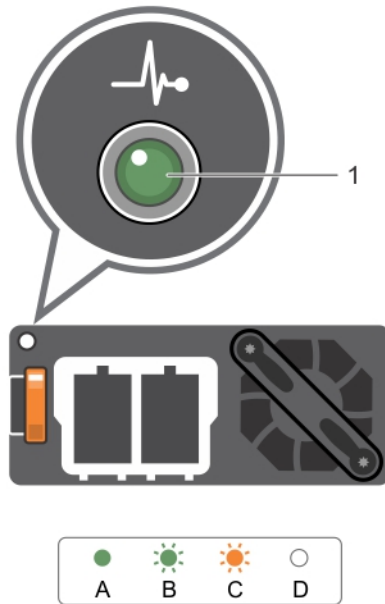

Convention	Power indicator pattern	Condition
		<p>△ CAUTION: When correcting a power supply unit mismatch, replace only the power supply unit with the flashing indicator. Swapping the opposite power supply unit to make a matched pair can result in an error condition and unexpected system shutdown. To change from a High Output configuration to a Low Output configuration or vice versa, you must turn off the system.</p> <p>△ CAUTION: AC power supply units support both 220 V and 110 V input voltages with the exception of Titanium power supply units, which support only 220 V. When two identical power supply units receive different input voltages, they can output different wattages, and trigger a mismatch.</p> <p>△ CAUTION: If two power supply units are used, they must be of the same type and have the same maximum output power.</p> <p>△ CAUTION: Combining AC and DC power supply units is not supported and triggers a mismatch.</p>
E	Not lit	Power supply unit is not connected.



**Figure 8. DC power supply unit status indicator**

1. DC power supply unit status indicator

**Table 10. DC Power indicator**

Convention	Power indicator pattern	Condition
A	Green	The handle or LED indicator glows green indicating that a valid power source is connected to the power supply unit and that the power supply unit is operational.
B	Flashing green	When hot-adding a power supply unit, power supply unit LED flashes green. This indicates that the power supply unit is mismatched with the other power supply unit (in terms of efficiency, feature set, health status, and supported voltage). Replace the power supply unit that has the flashing indicator with a power supply unit that matches the capacity of the other installed power supply unit.
C	Flashing amber	<p>Indicates a problem with the power supply unit.</p> <p> <b>CAUTION: When correcting a power supply unit mismatch, replace only the power supply unit with the flashing indicator. Swapping the opposite power supply unit to make a matched pair can result in an error condition and unexpected system shutdown. To change from a High Output configuration to a Low Output configuration or vice versa, you must turn off the system.</b></p> <p> <b>CAUTION: AC power supply units support both 220 V and 110 V input voltages with the exception of Titanium power supply units, which support only 220 V. When two identical power supply units receive different input voltages, they can output different wattages, and trigger a mismatch.</b></p> <p> <b>CAUTION: If two power supply units are used, they must be of the same type and have the same maximum output power.</b></p> <p> <b>CAUTION: Combining AC and DC power supply units is not supported and triggers a mismatch.</b></p>
D	Not lit	Power supply unit is not connected.

## Documentation references

For information about the Dell documents, see the Support Matrix specific for your product.

For information about the Nutanix documents that applies to a specific release of Nutanix solution software, see the Support Matrix specific for your product.

# Performing initial system configuration

After you receive your system, you must set up your system, install the operating system if it is not pre-installed, and set up and configure the system iDRAC IP address.

## Setting up your system

1. Unpack the server.
2. Install the server into the rack. For more information about installing the server into the rack, see your system *Rack Installation Placemat* at [Dell.com/xcseriesmanuals](http://Dell.com/xcseriesmanuals).
3. Connect the peripherals to the system.
4. Connect the system to its electrical outlet.
5. Turn on the system by pressing the Power button or by using iDRAC.
6. Turn on the attached peripherals.

## Methods of setting up and configuring the iDRAC IP address

You can set up the iDRAC IP address by using one of the following interfaces:

- iDRAC Settings utility
- Lifecycle Controller
- Dell Deployment Toolkit
- Server LCD panel

You can configure iDRAC IP by using:

1. iDRAC Web Interface.

For more information about setting up and configuring iDRAC, see the *Integrated Dell Remote Access Controller User's Guide* at [Dell.com/idracmanuals](http://Dell.com/idracmanuals).

2. Remote Access Controller Admin (RACADM).

For more information, see the *RACADM Command Line Interface Reference Guide* and the *Integrated Dell Remote Access Controller User's Guide* at [Dell.com/idracmanuals](http://Dell.com/idracmanuals).

3. Remote Services that includes Web Services Management (WS-Man). For more information, see the *Lifecycle Controller Remote Services Quick Start Guide* at [Dell.com/idracmanuals](http://Dell.com/idracmanuals).

## Logging in to iDRAC

You can log in to iDRAC as an iDRAC local user, a Microsoft Active Directory user, or a Lightweight Directory Access Protocol (LDAP) user. You can also log in by using Single Sign-On or a Smart Card. The

default user name is `root` and password is `calvin`. For more information about logging in to iDRAC and iDRAC licenses, see the *Integrated Dell Remote Access Controller User's Guide* at [Dell.com/idracmanuals](https://www.dell.com/support/manuals).

You can also access iDRAC by using RACADM. For more information, see the *RACADM Command Line Interface Reference Guide* and the *Integrated Dell Remote Access Controller User's Guide* at [Dell.com/idracmanuals](https://www.dell.com/support/manuals).

## Installing the operating system

If the server is shipped without an operating system, install the supported operating system on the server by using one of the following methods:

- Dell Systems Management Tools and Documentation media. See the operating system documentation at [Dell.com/operatingsystemmanuals](https://www.dell.com/support/manuals).
- Dell Lifecycle Controller. See the Lifecycle Controller documentation at [Dell.com/idracmanuals](https://www.dell.com/support/manuals).
- Dell OpenManage Deployment Toolkit. See the OpenManage documentation at [Dell.com/openmanagemanuals](https://www.dell.com/support/manuals).

For information about the list of operating systems supported on your system, see the operating systems support matrix at [Dell.com/ossupport](https://www.dell.com/support).

## Remote management

To perform out-of-band systems management by using iDRAC, you must configure iDRAC for remote accessibility, set up the management station and managed system, and configure the supported Web browsers. For more information, see the *Integrated Dell Remote Access Controller User's Guide* at [Dell.com/idracmanuals](https://www.dell.com/support/manuals).

You can also remotely monitor and manage the server by using the Dell OpenManage Server Administrator software application and OpenManage Essentials systems management console. For more information, go to [Dell.com/openmanagemanuals](https://www.dell.com/support/manuals).

## Downloading and installing drivers and firmware

Dell recommends that you download and install the latest BIOS, drivers, and systems management firmware on your system.

### Prerequisites

Ensure that you clear the web browser cache.

### Steps

1. Go to [Dell.com/support/home](https://www.dell.com/support/home).
2. Under Support in the Customized support section type your Service Tag into the **Enter your Service Tag** or **Express Service code** box.



**NOTE:** If you do not have the Service Tag, select **Detect My Product** to allow the system to automatically detect your Service Tag, or under **General support** select your product page.

3. Click **Drivers & downloads**.  
The drivers that are applicable to your selection are displayed.
4. Download the drivers you require to a diskette drive, USB drive, CD, or DVD.

# Pre-operating system management applications

The pre-operating system management applications for your system helps you manage different settings and features of your system without booting to the operating system.

Your system has the following pre-operating system management applications:

- System Setup
- Boot Manager
- Dell Lifecycle Controller

Dell Lifecycle Controller allows you to perform useful tasks such as configuring BIOS and hardware settings, deploying operating system, updating drivers, and saving hardware profiles. For more information about Dell Lifecycle Controller, see the documentation at [Dell.com/idracmanuals](http://Dell.com/idracmanuals).

## Navigation keys

The navigation keys can help you access the pre-operating system management applications.

<b>Page Up</b>	Moves to the previous screen.
<b>Page Down</b>	Moves to the next screen.
<b>Up arrow</b>	Moves to the previous field.
<b>Down arrow</b>	Moves to the next field.
<b>Enter</b>	Enables you to type a value in the selected field (if applicable) or follow the link in the field.
<b>Spacebar</b>	Expands or collapses a drop-down list, if applicable.
<b>Tab</b>	Moves to the next focus area.
	 <b>NOTE:</b> This feature is applicable for the standard graphical browser only.
<b>Esc</b>	Moves to the previous page until you view the main screen. Pressing Esc in the main screen exits System BIOS/iDRAC Settings/Device Settings/Service Tag Settings and proceeds with system boot.
<b>F1</b>	Displays the System Setup help.
<b>F2</b>	Enables you to enter <b>System Setup</b>
<b>F10</b>	Enables you to enter <b>Dell Lifecycle Controller</b>
<b>F11</b>	Enables you to enter <b>Boot Manager</b>

## About System Setup

Using System Setup, you can configure the BIOS settings, iDRAC settings, and device settings of your system.

 **NOTE:** There are a several generic server settings that appear during system setup that do not apply to this system, such as RAID or UEFI.

You can access System Setup in two methods:

- Standard Graphical Browser — This is enabled by default.
- Text Browser — This is enabled by using Console Redirection.

To enable Console Redirection:

- On the **System Setup** page, click **System BIOS**.
- On the **Serial Communications** page, click **Serial Communication**, and then select **On with Console Redirection**.

 **NOTE:** By default, help text for the selected field is displayed in the graphical browser. To view the help text in the text browser, press F1.

From System Setup, you can:

- Change the NVRAM settings after you add or remove hardware
- View the system hardware configuration
- Enable or disable integrated devices
- Set performance and power management thresholds
- Manage system security

## Entering System Setup

1. Turn on or restart your system.
2. Press F2 immediately after you see the following message:

```
F2 = System Setup
```

If your operating system begins to load before you press F2, allow the system to finish booting, and then restart your system and try again.

 **NOTE:** If an error message is displayed while the system is starting, make a note of the message. For more information, see [System messages](#).

 **NOTE:** After installing a memory upgrade, it is normal for your system to display a message the first time you start your system.

## System Setup Main Menu

Table 11. System setup main menu

Option	Description
<b>System BIOS</b>	Enables you to configure BIOS settings.
<b>iDRAC Settings</b>	Enables you to configure iDRAC settings. The iDRAC Settings utility is an interface to set up and configure the iDRAC parameters by using UEFI. You can enable or disable various iDRAC parameters by using the iDRAC Settings utility. For more information about this utility, see the <i>Integrated Dell Remote Access Controller User's Guide</i> at <a href="http://Dell.com/idracmanuals">Dell.com/idracmanuals</a> .
<b>Device Settings</b>	Enables you to configure device settings.

### Editing system BIOS screen settings

You can use the **System BIOS** screen to view the BIOS settings. You can also edit some of the settings such as Boot Order, System Password, Setup Password, and enable or disable USB ports.

Go to **System Setup Main Menu**, and then click **System BIOS**.

The **System BIOS** screen is displayed.

### System BIOS screen settings

The **System BIOS** screen details are explained below.

Table 12. System BIOS

Menu Item	Description
<b>System Information</b>	Displays information about the system such as the system model name, BIOS version and Service Tag.
<b>Memory Settings</b>	Displays information and options related to the installed memory.
<b>Processor Settings</b>	Displays information and options related to the processor such as speed, cache size, and so on.
<b>SATA Settings</b>	Displays options to enable or disable the integrated SATA controller and ports.
<b>Boot Settings</b>	Displays options to specify the boot mode (BIOS or UEFI). Enables you to modify UEFI and BIOS boot settings.
<b>Network Settings</b>	Displays options to change the network settings.
<b>Integrated Devices</b>	Displays options to enable or disable integrated device controllers and ports, and to specify related features and options.
<b>Serial Communication</b>	Displays options to enable or disable the serial ports and specify related features and options.
<b>System Profile Settings</b>	Displays options to change the processor power management settings, memory frequency, and so on.
<b>System Security</b>	Displays options to configure the system security settings like, system password, setup password, Trusted Platform Module (TPM) security, and

Menu Item	Description
	so on. It also enables or disables support for the power and NMI buttons on the system.
<b>Miscellaneous Settings</b>	Displays options to change the system date, time, and so on.

## Editing system information

You can use the **System Information** screen to view system properties such as Service Tag, system model, and the BIOS version.

1. Go to **System Setup Main Menu**, and then click **System BIOS**.
2. On the **System BIOS** screen, click **System Information**.  
The **System Information** screen is displayed.

### System information screen settings

The **System Information** screen details are explained as follows:

**Table 13. System information**

Menu Item	Description
<b>System Model Name</b>	Displays the system model name.
<b>System BIOS Version</b>	Displays the BIOS version installed on the system.
<b>System Management Engine Version</b>	Displays the current revision of the Management Engine firmware.
<b>System Service Tag</b>	Displays the system Service Tag.
<b>System Manufacturer</b>	Displays the name of the system manufacturer.
<b>System Manufacturer Contact Information</b>	Displays the contact information of the system manufacturer.
<b>System CPLD Version</b>	Displays the current revision of the system CPLD firmware.
<b>UEFI Compliance Version</b>	Displays the system firmware UEFI compliance level.

## Editing memory settings



You can use the **Memory Settings** screen to view all the memory settings. You can also enable or disable some memory configurations such as system memory testing and node interleaving.

1. Go to **System Setup Main Menu**, and then click **System BIOS**.
2. On the **System BIOS** screen, click **Memory Settings**.  
The **Memory Settings** screen displayed.

### Memory screen settings

The **Memory Settings** screen details are explained as follows:

Table 14. Memory settings

Menu Item	Description
<b>System Memory Size</b>	Displays the amount of memory installed in the system.
<b>System Memory Type</b>	Displays the type of memory installed in the system.
<b>System Memory Speed</b>	Displays the system memory speed.
<b>System Memory Voltage</b>	Displays the system memory voltage.
<b>Video Memory</b>	Displays the amount of video memory.
<b>System Memory Testing</b>	Specifies whether system memory tests are run during system boot. Options are <b>Enabled</b> and <b>Disabled</b> . By default, the <b>System Memory Testing</b> option is set to <b>Disabled</b> .
<b>Memory Operating Mode</b>	<p>Specifies the memory operating mode. The options available are <b>Optimizer Mode</b>, <b>Advanced ECC Mode</b>, <b>Mirror Mode</b>, <b>Spare Mode</b>, <b>Spare with Advanced ECC Mode</b>, and <b>Dell Fault Resilient Mode</b>. By default, the <b>Memory Operating Mode</b> option is set to <b>Optimizer Mode</b>.</p> <p> <b>NOTE:</b> The <b>Memory Operating Mode</b> can have different defaults and available options based on the memory configuration of your system.</p> <p> <b>NOTE:</b> The <b>Dell Fault Resilient Mode</b> establishes an area of memory that is fault resilient. This mode can be used by an operating system that supports the feature to load critical applications or enables the operating system kernel to maximize system availability.</p>
<b>Node Interleaving</b>	Specifies if Non-Uniform Memory architecture (NUMA) is supported. If this field is <b>Enabled</b> , memory interleaving is supported if a symmetric memory configuration is installed. If <b>Disabled</b> , the system supports NUMA (asymmetric) memory configurations. By default, <b>Node Interleaving</b> option is set to <b>Disabled</b> .
<b>Snoop Mode</b>	Specifies the Snoop Mode options. Snoop Mode options available are <b>Home Snoop</b> , <b>Early Snoop</b> , <b>Cluster on Die</b> . By default, the Snoop Mode option is set to <b>Early Snoop</b> . The field is only available when Node Interleaving is <b>Disabled</b> .

## Editing processor settings

You can use the **Processor Settings** screen to view the processor settings. You can also enable virtualization technology, hardware prefetcher, and logical processor idling.

1. Go to **System Setup Main Menu**, and then click **System BIOS**.
2. On the **System BIOS** screen, click **Processor Settings**.  
The **Processor Settings** screen displayed.

### Processor settings screen

The **Processor Settings** screen details are explained as follows:

Table 15. Processor settings

Menu Item	Description
<b>Logical Processor</b>	Enables or disables the logical processors and displays the number of logical processors. If the <b>Logical Processor</b> option is set to <b>Enabled</b> , the BIOS displays all the logical processors. If this option is set to <b>Disabled</b> , the BIOS only displays one logical processor per core. By default, the <b>Logical Processor</b> option is set to <b>Enabled</b> .
<b>Alternate RTID (Requestor Transaction ID) Setting</b>	Enables you to allocate more RTIDs to the remote socket, thereby increasing cache performance between the sockets or easing work in normal mode for NUMA. By default, the <b>Alternate RTID (Requestor Transaction ID) Setting</b> is set to <b>Disabled</b> .
<b>Virtualization Technology</b>	Enables or disables the additional hardware capabilities provided for virtualization. By default, the <b>Virtualization Technology</b> option is set to <b>Enabled</b> .
<b>Address Translation Service (ATS)</b>	Defines the Address Translation Cache (ATC) for devices to cache the DMA transactions. This field provides an interface to a chipset's Address Translation and Protection Table to translate DMA addresses to host addresses. By default, the option is set to <b>Enabled</b> .
<b>Adjacent Cache Line Prefetch</b>	Optimizes the system for applications that require high usage of sequential memory access. By default, the <b>Adjacent Cache Line Prefetch</b> option is set to <b>Enabled</b> . You can disable this option for applications that require high usage of random memory access.
<b>Hardware Prefetcher</b>	Enables or disables the hardware prefetcher. By default, the <b>Hardware Prefetcher</b> option is set to <b>Enabled</b> .
<b>DCU Streamer Prefetcher</b>	Allows you to enable or disable the Data Cache Unit (DCU) streamer prefetcher. By default, the <b>DCU Streamer Prefetcher</b> option is set to <b>Enabled</b> .
<b>DCU IP Prefetcher</b>	Enables or disables the Data Cache Unit (DCU) IP prefetcher. By default, the <b>DCU IP Prefetcher</b> option is set to <b>Enabled</b> .
<b>Execute Disable</b>	Enables or disables the execute disable memory protection technology. By default, the <b>Execute Disable</b> option is set to <b>Enabled</b> .
<b>Logical Processor Idling</b>	Enables or disables the operating system capability to put logical processors in the idling state in order to reduce power consumption. By default, the option is set to <b>Disabled</b> .
<b>Configurable TDP</b>	Allows reconfiguration of Thermal Design Power (TDP) to lower levels. TDP refers to the maximum amount of power the cooling system is required to dissipate.
<b>X2Apic Mode</b>	Enables or disables the X2Apic mode.
<b>Dell Controlled Turbo</b>	 <b>NOTE:</b> Depending on the number of installed CPUs, there may be up to four processor listings. Controls the turbo engagement. Enable this option only when <b>System Profile</b> is set to <b>Performance</b> .
<b>Number of Cores per Processor</b>	Controls the number of enabled cores in each processor. By default, the <b>Number of Cores per Processor</b> option is set to <b>All</b> .
<b>Processor 64-bit Support</b>	Specifies if the processor(s) support 64-bit extensions.

Menu Item	Description
Processor Core Speed	Displays the maximum core frequency of the processor.
Processor 1	<p> <b>NOTE:</b> Depending on the number of installed CPUs, there may be up to four processors listings. The following settings are displayed for each processor installed in the system.</p> <ul style="list-style-type: none"> <li>• <b>Family-Model-Stepping:</b> Displays the family, model and stepping of the processor as defined by Intel.</li> <li>• <b>Brand:</b> Displays the brand name reported by the processor.</li> <li>• <b>Level 2 Cache:</b> Displays the total L2 cache.</li> <li>• <b>Level 3 Cache:</b> Displays the total L3 cache.</li> <li>• <b>Number of Cores:</b> Displays the number of cores per processor.</li> </ul>

## Editing SATA Settings

You can use the **SATA Settings** screen to view the SATA settings of SATA devices and enable RAID on your system.

1. Go to **System Setup Main Menu**, and then click **System BIOS**.
2. On the **System BIOS** screen, click **SATA Settings**.  
The **SATA Settings** screen displayed.

### SATA settings screen

The **SATA Settings** screen details are explained below.

**Table 16. SATA settings**

Menu Item	Description
Embedded SATA	Enables the embedded SATA to be set to <b>Off</b> , <b>ATA</b> , <b>AHCI</b> , or <b>RAID</b> modes. By default, the <b>Embedded SATA</b> option is set to <b>AHCI</b> .
Security Freeze Lock	Sends Security Freeze Lock command to the Embedded SATA drives during POST. This option is applicable only to ATA and AHCI mode.
Write Cache	Enables or disables the command for Embedded SATA drives during POST.
Port A	<p>Sets the drive type of the selected device. For <b>Embedded SATA settings</b> in <b>ATA</b> mode, set this field to <b>Auto</b> to enable BIOS support. Set it to <b>OFF</b> to turn off BIOS support.</p> <p>For <b>AHCI</b> mode or <b>RAID</b> mode, BIOS always enables support.</p> <p><b>Model:</b> Displays the drive model of the selected device.</p> <p><b>Drive Type:</b> Displays the type of drive attached to the SATA port.</p> <p><b>Capacity:</b> Displays the total capacity of the hard drive. The field is undefined for removable media devices such as optical drives.</p>
Port B	Sets the drive type of the selected device. For <b>Embedded SATA settings</b> in <b>ATA</b> mode, set this field to <b>Auto</b> to enable BIOS support. Set it to <b>OFF</b> to turn off BIOS support.

Menu Item	Description
Port C	<p>For <b>AHCI</b> mode or <b>RAID</b> mode, BIOS always enables support.</p> <p><b>Model:</b> Displays the drive model of the selected device.</p> <p><b>Drive Type:</b> Displays the type of drive attached to the SATA port.</p> <p><b>Capacity:</b> Displays the total capacity of the hard drive. The field is undefined for removable media devices such as optical drives.</p>
Port D	<p>Sets the drive type of the selected device. For <b>Embedded SATA settings</b> in <b>ATA</b> mode, set this field to <b>Auto</b> to enable BIOS support. Set it to <b>OFF</b> to turn off BIOS support.</p> <p>For <b>AHCI</b> mode or <b>RAID</b> mode, BIOS always enables support.</p> <p><b>Model:</b> Displays the drive model of the selected device.</p> <p><b>Drive Type:</b> Displays the type of drive attached to the SATA port.</p> <p><b>Capacity:</b> Displays the total capacity of the hard drive. The field is undefined for removable media devices such as optical drives.</p>
Port E	<p>Sets the drive type of the selected device. For <b>Embedded SATA settings</b> in <b>ATA</b> mode, set this field to <b>Auto</b> to enable BIOS support. Set it to <b>OFF</b> to turn off BIOS support.</p> <p>For <b>AHCI</b> mode or <b>RAID</b> mode, BIOS always enables support.</p> <p><b>Model:</b> Displays the drive model of the selected device.</p> <p><b>Drive Type:</b> Displays the type of drive attached to the SATA port.</p> <p><b>Capacity:</b> Displays the total capacity of the hard drive. The field is undefined for removable media devices such as optical drives.</p>
Port F	<p>Sets the drive type of the selected device. For <b>Embedded SATA settings</b> in <b>ATA</b> mode, set this field to <b>Auto</b> to enable BIOS support. Set it to <b>OFF</b> to turn off BIOS support.</p> <p>For <b>AHCI</b> mode or <b>RAID</b> mode, BIOS always enables support.</p> <p><b>Model:</b> Displays the drive model of the selected device.</p> <p><b>Drive Type:</b> Displays the type of drive attached to the SATA port.</p>

Menu Item	Description
Port G	<p><b>Capacity:</b> Displays the total capacity of the hard drive. The field is undefined for removable media devices such as optical drives.</p> <p>Sets the drive type of the selected device. For <b>Embedded SATA settings</b> in <b>ATA</b> mode, set this field to <b>Auto</b> to enable BIOS support. Set it to <b>OFF</b> to turn off BIOS support. For <b>AHCI</b> mode or <b>RAID</b> mode, BIOS always enables support.</p> <p><b>Model:</b> Displays the drive model of the selected device.</p> <p><b>Drive Type:</b> Displays the type of drive attached to the SATA port.</p> <p><b>Capacity:</b> Displays the total capacity of the hard drive. The field is undefined for removable media devices such as optical drives.</p>
Port H	<p>Sets the drive type of the selected device. For <b>Embedded SATA settings</b> in <b>ATA</b> mode, set this field to <b>Auto</b> to enable BIOS support. Set it to <b>OFF</b> to turn off BIOS support. For <b>AHCI</b> mode or <b>RAID</b> mode, BIOS always enables support.</p> <p><b>Model:</b> Displays the drive model of the selected device.</p> <p><b>Drive Type:</b> Displays the type of drive attached to the SATA port.</p> <p><b>Capacity:</b> Displays the total capacity of the hard drive. The field is undefined for removable media devices such as optical drives.</p>
Port I	<p>Sets the drive type of the selected device. For <b>Embedded SATA settings</b> in <b>ATA</b> mode, set this field to <b>Auto</b> to enable BIOS support. Set it to <b>OFF</b> to turn off BIOS support. For <b>AHCI</b> mode or <b>RAID</b> mode, BIOS always enables support.</p> <p><b>Model:</b> Displays the drive model of the selected device.</p> <p><b>Drive Type:</b> Displays the type of drive attached to the SATA port.</p> <p><b>Capacity:</b> Displays the total capacity of the hard drive. The field is undefined for removable media devices such as optical drives.</p>
Port J	<p>Sets the drive type of the selected device. For <b>Embedded SATA settings</b> in <b>ATA</b> mode, set this field to <b>Auto</b> to enable BIOS support. Set it to <b>OFF</b> to turn off BIOS support. For <b>AHCI</b> mode or <b>RAID</b> mode, BIOS always enables support.</p> <p><b>Model:</b> Displays the drive model of the selected device.</p> <p><b>Drive Type:</b> Displays the type of drive attached to the SATA port.</p> <p><b>Capacity:</b> Displays the total capacity of the hard drive. The field is undefined for removable media devices such as optical drives.</p>

## Editing boot settings screen





You can use the **Boot Settings** screen to set the Boot mode to either **BIOS** or **UEFI**. It also allows you to specify the boot order.

1. Go to **System Setup Main Menu**, and then click **System BIOS**.
2. On the **System BIOS** screen, click **Boot Settings**.  
The **Boot Settings** screen displayed.

### Boot Settings

The **Boot Settings** screen details are explained as follows:

Table 17. Boot settings

Menu Item	Description
<b>Boot Mode</b>	<p>Enables you to set the boot mode of the system.</p> <p> <b>NOTE:</b> This system supports only BIOS boot mode.</p> <p> <b>CAUTION: Switching the boot mode may prevent the system from booting if the operating system is not installed in the same boot mode.</b></p> <p> <b>NOTE:</b> Setting this field to <b>UEFI</b> disables the <b>BIOS Boot Settings</b> menu. Setting this field to <b>BIOS</b> disables the <b>UEFI Boot Settings</b> menu.</p> <p>If the operating system supports UEFI, you can set this option to <b>UEFI</b>. Setting this field to <b>BIOS</b> allows compatibility with non-UEFI operating systems. By default, the <b>Boot Mode</b> option is set to <b>BIOS</b>.</p> <p> <b>NOTE:</b> This system supports only BIOS boot mode.</p>
<b>Boot Sequence Retry</b>	<p>Enables or disables the Boot Sequence Retry feature. If this field is enabled and the system fails to boot, the system reattempts the boot sequence after 30 seconds. By default, the <b>Boot Sequence Retry</b> option is set to <b>Enabled</b>.</p>
<b>Hard-Disk Failover</b>	<p>Specifies which devices in the <b>Hard-Disk Drive Sequence</b> are attempted in the boot sequence. When the option is <b>Disabled</b>, only the first hard disk device in the list is attempted to boot. When set to <b>Enabled</b>, all hard disk devices are attempted in order, as listed in the <b>Hard-Disk Drive Sequence</b>. This option is not enabled for UEFI Boot Mode.</p>
<b>Boot Option Settings</b>	<p>Configures the boot sequence and the boot devices.</p>

## Editing network settings

You can use the **Network Settings** screen to modify Preboot eXecution Environment (PXE) device settings. Network Settings are only available in UEFI boot mode. BIOS does not control network settings in the BIOS boot mode. For BIOS boot mode, the network settings are handled by the network controllers option ROM.

1. Go to **System Setup Main Menu**, and then click **System BIOS**.
2. On the **System BIOS** screen, click **Network Settings**.

The **Network Settings** screen displayed.

## Network settings screen

The **Network Settings** screen details are explained as follows:

**Table 18. Network settings**

Menu Item	Description
<b>PXE Device n</b> (n = 1 to 4)	Enables or disables the device. When enabled, a UEFI boot option is created for the device.
<b>PXE Device n Settings</b> (n = 1 to 4)	Allows you to control the configuration of the PXE device.

## Editing integrated devices details

You can use the **Integrated Devices** screen to view and configure the settings of all integrated devices including the video controller, integrated RAID controller, and the USB ports.



1. Go to **System Setup Main Menu**, and then click **System BIOS**.
2. On the **System BIOS** screen, click **Integrated Devices**.

The **Integrated Devices** screen displayed.

## Integrated devices screen details

The **Integrated Devices** screen details are explained below.

**Table 19. Integrated devices**

Menu Item	Description
<b>USB 3.0 Setting</b>	Enables or disables the USB 3.0 support. Enable this option only if your operating system supports USB 3.0. If you disable this option, devices operate at USB 2.0 speed. USB 3.0 is disabled by default.
<b>User Accessible USB Ports</b>	Enables or disables the USB ports. Selecting <b>Only Back Ports On</b> disables the front USB ports, selecting <b>All Ports Off</b> disables all USB ports. The USB keyboard and mouse operates during boot process in certain operating systems. After the boot process is complete, the USB keyboard and mouse do not work if the ports are disabled.  <b>NOTE:</b> Selecting <b>Only Back Ports On</b> and <b>All Ports Off</b> disables the USB management port and also restrict access to iDRAC features.
<b>Internal USB Port</b>	Enables or disables the internal USB port. By default, the option is set to <b>Enabled</b> .
<b>Integrated RAID Controller</b>	Enables or disables the integrated RAID controller. By default, the option is set to <b>Enabled</b> .
<b>Integrated Network Card 1</b>	Enables or disables the integrated network card.
<b>Embedded NIC1 and NIC2</b>	 <b>NOTE:</b> The Embedded NIC1 and NIC2 option is only available on systems that do not have <b>Integrated Network Card 1</b> . Enables or disables the Embedded NIC1 and NIC2 . If set to <b>Disabled</b> , the NIC may still be available for shared network access by the embedded

Menu Item	Description
	management controller. The embedded NIC1 and NIC2 option is only available on systems that do not have NDCs. This option is mutually exclusive with the Integrated Network Card 1 option. Configure this function using the NIC management utilities of the system.
<b>I/OAT DMA Engine</b>	Enables or disables the I/OAT option. Enable only if the hardware and software support the feature.
<b>Embedded Video Controller</b>	Enables or disables the <b>Embedded Video Controller</b> . By default, the embedded video controller is <b>Enabled</b> . <b>Current state of Embedded Video Controller</b> is <b>Enabled</b> . <b>Current State of Embedded Video Controller</b> is a read only field, indicating the current state for the Embedded Video Controller. If the Embedded Video Controller is the only display capability in the system (that is, no add-in graphics card is installed), then the Embedded Video Controller is automatically used as the primary display even if the Embedded Video Controller setting is <b>Disabled</b> .
<b>Current State of Embedded Video Controller</b>	Displays the current state of the <b>Embedded Video Controller</b> . <b>Current State of Embedded Video Controller</b> is a read only field, indicating the current state for the Embedded Video Controller.
<b>SR-IOV Global Enable</b>	Enables or disables the BIOS configuration of Single Root I/O Virtualization (SR-IOV) devices. By default, the <b>SR-IOV Global Enable</b> option is set to <b>Enabled</b> .
<b>OS Watchdog Timer</b>	If your system stops responding, this OS Watchdog Timer aids in the recovery of your operating system. When this field is set to <b>Enabled</b> , the operating system is allowed to initialize the timer. When the option is set to <b>Disabled</b> (the default), the timer has no effect on the system.
<b>Memory Mapped I/O above 4GB</b>	Enables or disables the support for PCIe devices that require large amounts of memory. By default, the option is set to <b>Enabled</b> .
<b>Slot Disablement</b>	Enables or disables the available PCIe slots on your system. The <b>Slot Disablement</b> feature controls the configuration of PCIe cards installed in the specified slot. Slot disablement must be used only when the installed peripheral card is preventing booting into the operating system or causing delays in system startup. If the slot is disabled, both the Option ROM and UEFI driver are disabled.

## Editing serial communication settings





You can use the **Serial Communication** screen to view the properties of the serial communication port.

1. Go to **System Setup Main Menu**, and then click **System BIOS**.
2. On the **System BIOS** screen, click **Serial Communication**.  
The **Serial Communication** screen is displayed.

### Serial Communication screen settings

The **Serial Communication** screen details are explained below.

Table 20. Serial communication

Menu Item	Description
<b>Serial Communication</b>	Selects serial communication devices (Serial Device 1 and Serial Device 2) in the BIOS. This is where you can select BIOS console redirection and specify the port address. By default, <b>Serial Communication</b> option is set to <b>Auto</b> .
<b>Serial Port Address</b>	<p>With Serial Communication, you can set the port address for serial devices. By default, the <b>Serial Port Address</b> option is set to <b>Serial Device 1=COM2, Serial Device 2=COM1</b></p> <p> <b>NOTE:</b> You can only use Serial Device 2 for Serial Over LAN (SOL). To use console redirection by SOL, configure the same port address for console redirection and the serial device.</p> <p> <b>NOTE:</b> Every time the system boots, the BIOS syncs the serial MUX setting saved in iDRAC. The serial MUX setting can independently be changed in iDRAC. Therefore, loading the BIOS default settings from within the BIOS setup utility may not always revert this setting to the default setting of Serial Device 1.</p>
<b>External Serial Connector</b>	<p>With the External Serial Connector, you can associate the External Serial Connector to Serial Device 1, Serial Device 2, or the Remote Access Device using this field.</p> <p> <b>NOTE:</b> You can only use Serial Device 2 for Serial Over LAN (SOL). To use console redirection by SOL, configure the same port address for console redirection and the serial device.</p> <p> <b>NOTE:</b> Every time the system boots, the BIOS syncs the serial MUX setting saved in iDRAC. The serial MUX setting can independently be changed in iDRAC. Therefore, loading the BIOS default settings from within the BIOS setup utility may not always revert this setting to the default setting of Serial Device 1.</p>
<b>Failsafe Baud Rate</b>	Displays the Failsafe baud rate for console redirection. The BIOS attempts to determine the baud rate automatically. This Failsafe baud rate is used only if the attempt fails, and the value must not be changed. By default, the <b>Failsafe Baud Rate</b> option is set to <b>115200</b> .
<b>Remote Terminal Type</b>	Sets the remote console terminal type. By default, the <b>Remote Terminal Type</b> option is set to <b>VT 100/VT 220</b> .
<b>Redirection After Boot</b>	Enables or disables the BIOS console redirection when the operating system is loaded. By default, the <b>Redirection After Boot</b> option is set to <b>Enabled</b> .

## Editing system profile



You can use the **System Profile Settings** screen to enable system performance settings such as power management.



1. Go to **System Setup Main Menu**, and then click **System BIOS**.
2. On the **System BIOS** screen, click **System Profile Settings**.  
The **System Profile Settings** screen is displayed.

## System profile screen settings

The **System Profile Settings** screen details are explained as follows:

**Table 21. System profile settings**

Menu Item	Description
<b>System Profile</b>	<p>Sets the system profile. If you set the <b>System Profile</b> option to a mode other than <b>Custom</b>, the BIOS automatically sets the rest of the options. You can only change the rest of the options if the mode is set to <b>Custom</b>. By default, the <b>System Profile</b> option is set to <b>Performance Per Watt Optimized (DAPC)</b>. DAPC is Dell Active Power Controller.</p> <p> <b>NOTE:</b> The following parameters are available only when the <b>System Profile</b> is set to <b>Custom</b>.</p> <ul style="list-style-type: none"> <li>• <b>CPU Power Management:</b> Sets the CPU power management. By default, the <b>CPU Power Management</b> option is set to <b>System DBPM (DAPC)</b>. DBPM is Demand-Based Power Management.</li> <li>• <b>Memory Frequency:</b> Sets the speed of the system memory. You can select <b>Maximum Performance</b>, <b>Maximum Reliability</b>, or a specific speed.</li> <li>• <b>Turbo Boost:</b> Enables or disables the processor to operate in turbo boost mode. By default, the <b>Turbo Boost</b> option is set to <b>Enabled</b>.</li> <li>• <b>Energy Efficient Turbo:</b> Enables or disables the <b>Energy Efficient Turbo</b>. Energy Efficient Turbo (EET) is a mode of operation where a processor's core frequency is adjusted within the turbo range based on workload.</li> <li>• <b>C1E:</b> Enables or disables the processor to switch to a minimum performance state when it is idle. By default, the <b>C1E</b> option is set to <b>Enabled</b>.</li> <li>• <b>C States:</b> Enables or disables the processor to operate in all available power states. By default, the <b>C States</b> option is set to <b>Enabled</b>.</li> <li>• <b>Collaborative CPU Performance Control:</b> Enables or disables the CPU power management. When set to <b>Enabled</b>, the CPU power management is controlled by the OS DBPM and the System DBPM (DAPC). By default, the option is set to <b>Disabled</b>.</li> <li>• <b>Memory Patrol Scrub:</b> Sets the memory patrol scrub frequency. By default, the <b>Memory Patrol Scrub</b> option is set to <b>Standard</b>.</li> <li>• <b>Memory Refresh Rate:</b> Sets the memory refresh rate to either 1x or 2x. By default, the <b>Memory Refresh Rate</b> option is set to <b>1x</b>.</li> <li>• <b>Uncore Frequency:</b> Selects the <b>Processor Uncore Frequency</b>. Dynamic mode allows the processor to optimize power resources across the cores and uncore during runtime. The optimization of the uncore frequency to either save power or optimize performance is influenced by the setting of the <b>Energy Efficiency Policy</b>.</li> <li>• <b>Energy Efficient Policy:</b> Enables you to select the <b>Energy Efficient Policy</b>. The CPU uses the setting to manipulate the internal behavior of the processor and determines whether to target higher performance or better power savings.</li> <li>• <b>Number of Turbo Boot Enabled Cores for Processor 1:</b> <p> <b>NOTE:</b> If there are two processors installed in the system, you see an entry for <b>Number of Turbo Boost Enabled Cores for Processor 2</b>.</p> <p>Controls the number of turbo boost enabled cores for processor 1. By default, the maximum number of cores is enabled.</p> </li> <li>• <b>Monitor/Mwait:</b> Enables the Monitor/Mwait instructions in the processor. By default, the Monitor/Mwait option is set to <b>Enabled</b> for all system profiles, except <b>Custom</b>.</li> </ul>

Menu Item	Description
	 <b>NOTE:</b> You can only disable this option if <b>C States</b> option in <b>Custom</b> mode is disabled.
	 <b>NOTE:</b> When <b>C States</b> is enabled in <b>Custom</b> mode, changing the Monitor/Mwait setting does not impact system power/performance.

## Editing system security



You can use the **System Security** screen to edit some settings such as setting the system password, setup password and disabling the power button.

1. Go to **System Setup Main Menu**, and then click **System BIOS**.
2. On the **System BIOS** screen, click **System Security**.  
The **System Security** screen is displayed.

### System security screen settings

The **System Security Settings** screen details are explained as follows:

**Table 22. System security settings**

Menu Item	Description
<b>Intel AES-NI</b>	Improves the speed of applications by performing encryption and decryption using the Advanced Encryption Standard Instruction Set and is set to <b>Enabled</b> by default.
<b>System Password</b>	Sets the system password. This option is set to <b>Enabled</b> by default and is read-only if the password jumper is not installed in the system.
<b>Setup Password</b>	Sets the setup password. This option is read-only if the password jumper is not installed in the system.
<b>Password Status</b>	Locks the system password. By default, the <b>Password Status</b> option is set to <b>Unlocked</b> .
<b>TPM Security</b>	 <b>NOTE:</b> The TPM menu is available only when the TPM module is installed.  Allows you to control the reporting mode of the Trusted Platform Module (TPM). By default, the <b>TPM Security</b> option is set to <b>Off</b> . You can only modify the TPM Status, TPM Activation, and Intel TXT fields if the <b>TPM Status</b> field is set to either <b>On with Pre-boot Measurements</b> or <b>On without Pre-boot Measurements</b> .
<b>TPM Information</b>	Changes the operational state of the TPM. By default, the <b>TPM Activation</b> option is set to <b>No Change</b> .
<b>TPM Status</b>	Displays the TPM status.
<b>TPM Command</b>	 <b>CAUTION:</b> Clearing the TPM results in the loss of all keys in the TPM. The loss of TPM keys may affect booting to the operating system.  Clears all the contents of the TPM. By default, the <b>TPM Clear</b> option is set to <b>No</b> .
<b>Intel TXT</b>	Enables or disables the Intel Trusted Execution Technology (TXT). To enable <b>Intel TXT</b> , Virtualization Technology must be enabled and TPM

Menu Item	Description
	Security must be <b>Enabled</b> with Pre-boot measurements. By default, the <b>Intel TXT</b> option is set to <b>Off</b>
<b>Power Button</b>	Enables or disables the Power button on the front of the system. By default, the <b>Power Button</b> option is set to <b>Enabled</b> .
<b>NMI Button</b>	Enables or disables the NMI button on the front of the system. By default, the <b>NMI Button</b> option is set to <b>Disabled</b> .
<b>AC Power Recovery</b>	Sets how the system reacts after AC power is restored to the system. By default, the <b>AC Power Recovery</b> option is set to <b>Last</b> .
<b>AC Power Recovery Delay</b>	Sets how the system supports staggering of power up after AC power is restored to the system. By default, the <b>AC Power Recovery Delay</b> option is set to <b>Immediate</b> .
<b>User Defined Delay (60s to 240s)</b>	Sets the <b>User Defined Delay</b> when the <b>User Defined</b> option for <b>AC Power Recovery Delay</b> is selected.
<b>UEFI Variable Access</b>	Provides varying degrees of securing UEFI variables. When set to <b>Standard</b> (the default) UEFI variables are accessible in the Operating System per the UEFI specification. When set to <b>Controlled</b> , selected UEFI variables are protected in the environment and new UEFI boot entries are forced to be at the end of the current boot order.
<b>Secure Boot</b>	Enables Secure Boot, where the BIOS authenticates each pre-boot image using the certificates in the Secure Boot Policy. Secure Boot is disabled by default.
<b>Secure Boot Policy</b>	When Secure Boot policy is <b>Standard</b> , the BIOS uses the system manufacturer's key and certificates to authenticate pre-boot images. When Secure Boot policy is <b>Custom</b> , the BIOS uses the user-defined key and certificates. Secure Boot policy is <b>Standard</b> by default.
<b>Secure Boot Policy Summary</b>	Displays the list of certificates and hashes that secure boot uses to authenticate images.

### **Secure Boot Custom Policy Settings screen**

Secure Boot Custom Policy Settings is displayed only when **Secure Boot Policy** is set to **Custom**. In the **System Setup Main Menu**, click **System BIOS** → **System Security** → **Secure Boot Custom Policy Settings**.

The **Secure Boot Custom Policy Settings** screen details are explained as follows:

**Table 23. Secure boot custom policy settings**

Menu Item	Description
<b>Platform Key</b>	Imports, exports, deletes, or restores the platform key (PK).
<b>Key Exchange Key Database</b>	Allows you to import, export, delete, or restore entries in the Key Exchange Key (KEK) Database.
<b>Authorized Signature Database</b>	Imports, exports, deletes, or restores entries in the Authorized Signature Database (db).
<b>Forbidden Signature Database</b>	Imports, exports, deletes, or restores entries in the Forbidden Signature Database (dbx).

## Editing miscellaneous settings



You can use the **Miscellaneous Settings** screen to perform some configurations such as updating the asset tag, and changing the system date and time.

1. Go to **System Setup Main Menu**, and then click **System BIOS**.
2. On the **System BIOS** screen, click **Miscellaneous Settings**.  
The **Miscellaneous Settings** screen displays.

### Miscellaneous settings screen

The **Miscellaneous Settings** screen details are explained as follows:

Table 24. Miscellaneous settings

Menu Item	Description
<b>System Time</b>	System Time lets you set the time on the system.
<b>System Date</b>	System Date lets you set the date on the system.
<b>Asset Tag</b>	Displays the asset tag and lets you to modify it for security and tracking purposes.
<b>Keyboard NumLock</b>	Keyboard NumLock lets you set whether the system boots with the NumLock enabled or disabled. By default the <b>Keyboard NumLock</b> is set to <b>On</b> .  <b>NOTE:</b> This option does not apply to 84-key keyboards.
<b>F1/F2 Prompt on Error</b>	Enables or disables the F1/F2 prompt on error. By default, <b>F1/F2 Prompt on Error</b> is set to <b>Enabled</b> . The F1/F2 prompt also includes keyboard errors.
<b>Load Legacy Video Option ROM</b>	You can determine whether the system BIOS loads the legacy video (INT 10H) option ROM from the video controller. Selecting <b>Enabled</b> in the operating system does not support UEFI video output standards. This field is only for UEFI boot mode. You cannot set this to <b>Enabled</b> if <b>UEFI Secure Boot</b> mode is enabled.
<b>In-System Characterization</b>	This option enables or disables <b>In-System Characterization</b> . By default, <b>In-System Characterization</b> is set to <b>Disabled</b> . The two other options are <b>Enabled</b> and <b>Enabled - No Reboot</b> .  <b>NOTE:</b> The default setting for <b>In-System Characterization</b> is subject to change in future BIOS releases.  When enabled, In-System Characterization (ISC) runs during POST upon detecting relevant change(s) in system configuration to optimize system power and performance. ISC takes about 20 seconds to run, and system reset is required for ISC results to be applied. The <b>Enabled - No Reboot</b>

Menu Item	Description
	option runs ISC and continues without applying ISC results until the next time system reset occurs. The <b>Enabled</b> option runs ISC and forces an immediate system reset so that ISC results can be applied. It takes the system longer to be ready due to the forced system reset. When disabled, ISC does not run.

## About Boot Manager

With Boot Manager you can add, delete, and arrange boot options. You can also access System Setup and boot options without restarting the system.

### Entering Boot Manager

The **Boot Manager** screen allows you to select boot options and diagnostic utilities.

1. Turn on or restart your system.
2. Press F11 when you see the message `F11 = Boot Manager`.  
If your operating system begins to load before you press F11, allow the system to finish booting, and then restart your system and try again.

### Boot Manager main menu

<b>Continue Normal Boot</b>	The system attempts to boot to devices starting with the first item in the boot order. If the boot attempt fails, the system continues with the next item in the boot order until the boot is successful or no more boot options are found.
<b>One Shot Boot Menu</b>	Displays the boot menu where you can select a one time boot device to boot from.
<b>Launch System Setup</b>	Allows you to access the System Setup.
<b>Launch Lifecycle Controller</b>	Closes the Boot Manager and invokes the Dell Lifecycle Controller program.
<b>System Utilities</b>	Opens system utilities menu such as system diagnostics and UEFI shell.

## Changing the boot order

You may have to change the boot order if you want to boot from a USB key or an optical drive. The instructions given here may vary if you have selected **BIOS** for **Boot Mode**.

1. On the **System Setup Main Menu** screen, click **System BIOS** → **Boot Settings**.
2. Click **Boot Option Settings** → **Boot Sequence**.
3. Use the arrow keys to select a boot device, and use the + and - keys to move the device down-or up in the order.
4. Click **Exit**, and then click **Yes** to save the settings on exit.

## Choosing the system boot mode

With System Setup, you can specify the boot mode for installing your operating system:

- BIOS boot mode (the default) is the standard BIOS-level boot interface.
- UEFI boot mode is an enhanced 64-bit boot interface based on Unified Extensible Firmware Interface (UEFI) specifications that overlays the system BIOS.

You must select the boot mode in the **Boot Mode** field of the **Boot Settings** screen of System Setup. Once you specify the boot mode, the system boots in the specified boot mode and you then proceed to install your operating system from that mode. Thereafter, you must boot the system in the same boot mode (BIOS or UEFI) to access the installed operating system. Trying to boot the operating system from the other boot mode causes the system to halt at startup.

 **NOTE:** Operating systems must be UEFI-compatible to be installed from the UEFI boot mode. DOS and 32-bit operating systems do not support UEFI and can only be installed from the BIOS boot mode.

 **NOTE:** For the latest information on supported operating systems, go to [Dell.com/ossupport](http://Dell.com/ossupport).

## Assigning a system and setup password

### Prerequisites

 **NOTE:** The password jumper enables or disables the System Password and Setup Password features. For more information about the password jumper settings, see [System board connectors](#).

You can assign a new **System Password** and **Setup Password** or change an existing **System Password** and **Setup Password** only when the password jumper setting is **enabled** and **Password Status** is **Unlocked**.

If the password jumper setting is disabled, the existing **System Password** and **Setup Password** are deleted and you need not provide the system password to boot the system.

### About this task

To assign a **System Password** and **Setup Password**, follow the steps below:

### Steps

1. To go to system setup, press F2 immediately after a power-on or reboot.
2. On the **System Setup Main Menu** screen, select **System BIOS**, and then press Enter.
3. On the **System BIOS** screen, select **System Security**, and then press Enter.
4. On the **System Security** screen, verify that **Password Status** is **Unlocked**.
5. Select **System Password**, enter your system password, and then press Enter or Tab.

Use the following guidelines to assign the system password:

- A password can have up to 32 characters.
- The password can contain the numbers 0 through 9.
- Only the following special characters are allowed: white space, ("), (+), (,), (-), (.), (/), (:), (|), (\), (|), (^).

A message prompts you to reenter the system password.

6. Reenter the system password and click **OK**.

7. Select **Setup Password**, enter your system password and press Enter or Tab.  
A message prompts you to re-enter the setup password.
8. Reenter the setup password and click **OK**.
9. Press Esc to return to the **System BIOS** screen. Press Esc again.  
A message prompts you to save the changes.



**NOTE:** Password protection does not take effect until the system reboots.

## Deleting or changing an existing system password and setup password

### Prerequisites

Ensure that the Password jumper is set to enabled and the **Password Status** is **Unlocked** before attempting to delete or change the existing System and/or Setup password. You cannot delete or change an existing System or Setup password if the **Password Status** is **Locked**.







### Steps

1. To go to system setup, press F2 immediately after a power on or restart.
2. On the **System Setup Main Menu** screen, select **System BIOS**, and then press Enter.  
The **System BIOS** screen is displayed.
3. On the **System BIOS** screen, select **System Security**, and then press Enter.  
The **System Security** screen is displayed.
4. On the **System Security** screen, verify that **Password Status** is **Unlocked**.
5. Select **System Password**, alter or delete the existing system password and press Enter or Tab.
6. Select **Setup Password**, alter or delete the existing setup password and press Enter or Tab.  
If you change the System and Setup password a message prompts you to reenter the new password.  
If you delete the System and Setup password, a message prompts you to confirm the deletion.
7. Press Esc to return to the **System BIOS** screen. Press Esc again, and a message prompts you to save the changes.

# Installing and removing system components

This section provides information about installing and removing the system components.

## Safety instructions

-  **WARNING:** Whenever you need to lift the system, get others to assist you. To avoid injury, do not attempt to lift the system by yourself.
-  **WARNING:** Opening or removing the system cover when the system is on may expose you to a risk of electric shock.
-  **CAUTION:** Do not operate the system without the cover for a duration exceeding five minutes.
-  **NOTE:** Operating the system without the system cover can result in component damage.
-  **CAUTION:** Many repairs may only be done by a certified service technician. You should only perform troubleshooting and simple repairs as authorized in your product documentation, or as directed by the online or telephone service and support team. Damage due to servicing that is not authorized by Dell is not covered by your warranty. Read and follow the safety instructions that came with the product.
-  **NOTE:** Dell recommends that you always use a static mat and static strap while working on components inside the system.
-  **NOTE:** To ensure proper operation and cooling, you must populate all bays in the system at all times with either a module or with a blank.

## Before working inside your system

1. Turn off the system, including any attached peripherals.
2. Disconnect the system from the electrical outlet and disconnect the peripherals.
3. If installed, remove the front bezel.  
For more information, see [Removing the front bezel](#).
4. Remove the system cover.  
For more information, see [Removing the system cover](#).

## After working inside your system

1. Install the system cover.

For more information, see [Installing the system cover](#).

2. Install the optional bezel.

For more information, see [Installing the front bezel](#).

3. Reconnect the system to its electrical outlet and peripherals.
4. Turn the system on, including any attached peripherals.

## Recommended tools

You need the following tools to perform the removal and installation procedures:

- Key to the bezel lock. This is only required when you have a bezel.
- #2 Phillips screwdriver
- #1 Phillips screwdriver
- T6, T8, T10, and T15 Torx screwdrivers

The following tools are required for assembling cables for a DC power supply unit (PSU):

- AMP 90871-1 hand-crimping tool or equivalent
- Tyco Electronics 58433-3 or equivalent
- Wire-stripper pliers capable of removing insulation from size 10 AWG solid or stranded, insulated copper wire

 **NOTE:** Use alpha wire part number 3080 or equivalent (65/30 stranding).

## Front bezel

### Removing the front bezel

1. Unlock the bezel lock at the left end of the bezel.
2. Lift the release latch next to the bezel lock.
3. Pull the left end of the bezel, unhook the right end and remove the bezel.

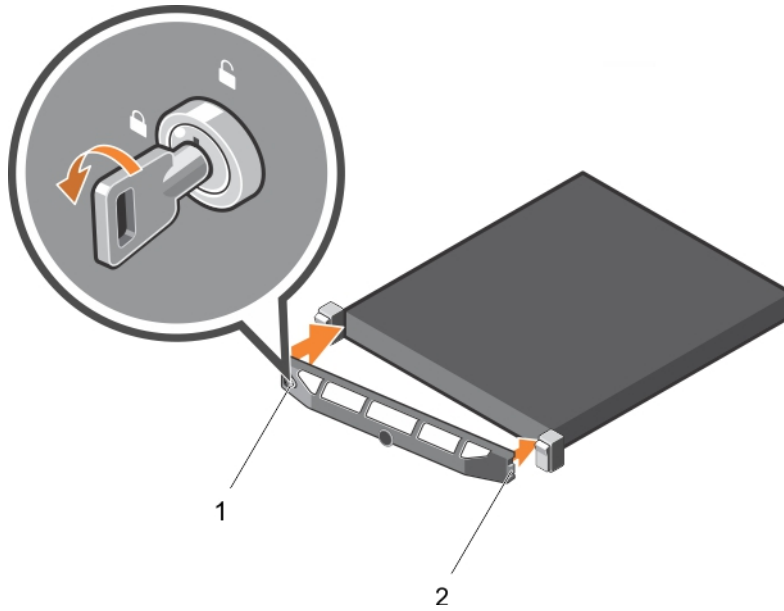

Figure 9. Removing and installing the front bezel

## Installing the front bezel

1. Hook the right end of the bezel onto the chassis.
2. Fit the free end of the bezel onto the system.
3. Secure the bezel with the keylock.

## Removing the system cover

### Prerequisites

1. Follow the safety guidelines listed in the Safety instructions section.
2. If installed, remove the optional bezel. For more information, see the Removing the optional front bezel section.

### Steps

1. Rotate the latch release lock counter clockwise to the unlocked position.
2. Lift the latch toward the back of the system.

The system cover slides back and the tabs on the system cover disengage from the slots on the chassis.



**NOTE:** The position of the latch may vary depending on the configuration of your system.

3. Hold the cover on both sides, and lift the cover away from the system.

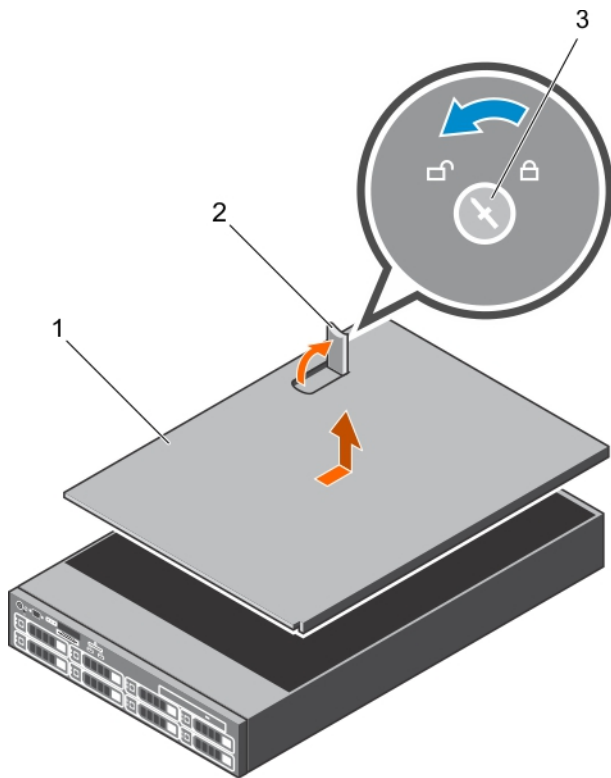

**Figure 10. Removing the system cover**

1. system cover
2. latch
3. latch release lock

#### **Next steps**

1. Install the system cover.

## **Installing the system cover**

#### **Prerequisites**

Ensure that you read the [.Safety instructions.](#)

#### **Steps**

1. Align the slots of the system cover with the tabs on the chassis.
2. Press the cover release latch, and push the cover toward the front of the chassis until the latch locks into place.
3. Turn the latch release lock clockwise to the locked position.
4. Install the optional bezel.
5. Reconnect the system to its electrical outlet and turn the system on, including any attached peripherals.

## Inside the system

**CAUTION:** Many repairs may only be done by a certified service technician. You should only perform troubleshooting and simple repairs as authorized in your product documentation, or as directed by the online or telephone service and support team. Damage due to servicing that is not authorized by Dell is not covered by your warranty. Read and follow the safety instructions that came with the product.

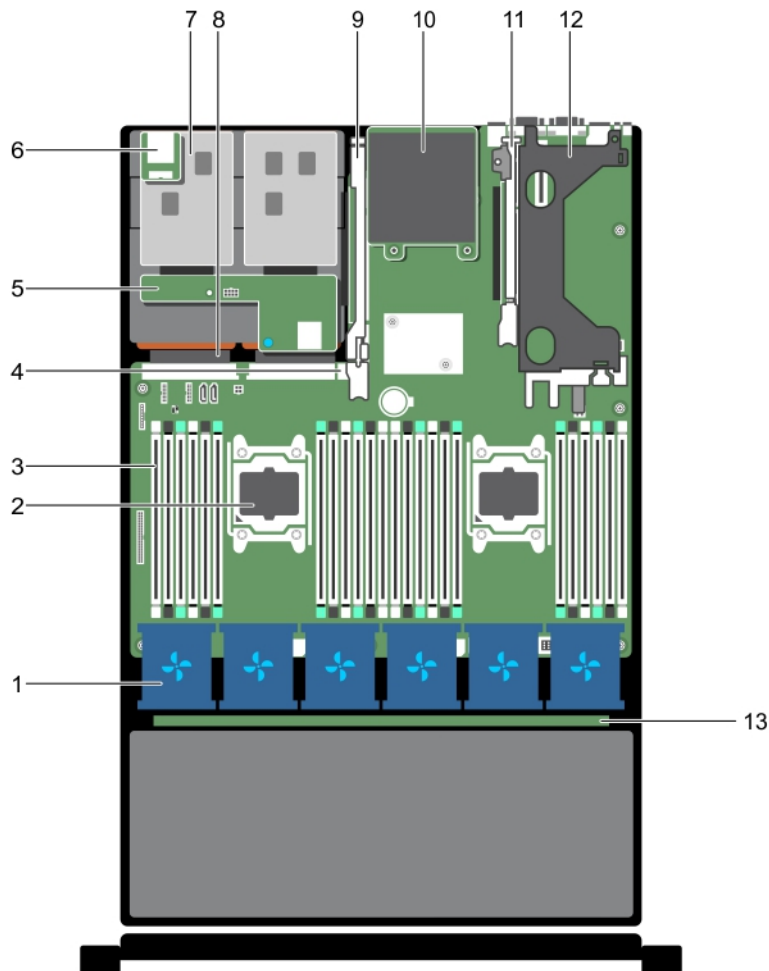

**Figure 11. Inside the system—Dell XC730xd-12C**

- |  |                            |
|--|----------------------------|
| 1. cooling-fan in the cooling-fan assembly (6) | 2. processor (2)           |
| 3. DIMMs (24)                                  | 4. internal USB port       |
| 5. hard-drive backplane (back)                 | 6. vFlash media slot       |
| 7. hard drive (2) (back)                       | 8. power supply unit (2)   |
| 9. expansion-card riser 3                      | 10. network daughter card  |
| 11. expansion-card riser 2                     | 12. expansion-card riser 1 |

## Cooling shroud

### Removing the cooling shroud

#### Prerequisites

**CAUTION:** Many repairs may only be done by a certified service technician. You should only perform troubleshooting and simple repairs as authorized in your product documentation, or as directed by the online or telephone service and support team. Damage due to servicing that is not authorized by Dell is not covered by your warranty. Read and follow the safety instructions that came with the product.

1. Ensure that you read the [Safety instructions](#).
2. Follow the procedure listed in [Before working inside your system](#).

**CAUTION:** Never operate your system with the cooling shroud removed. The system may get overheated quickly, resulting in shutdown of the system and loss of data.

#### Steps

Hold the shroud and lift it away from the system.

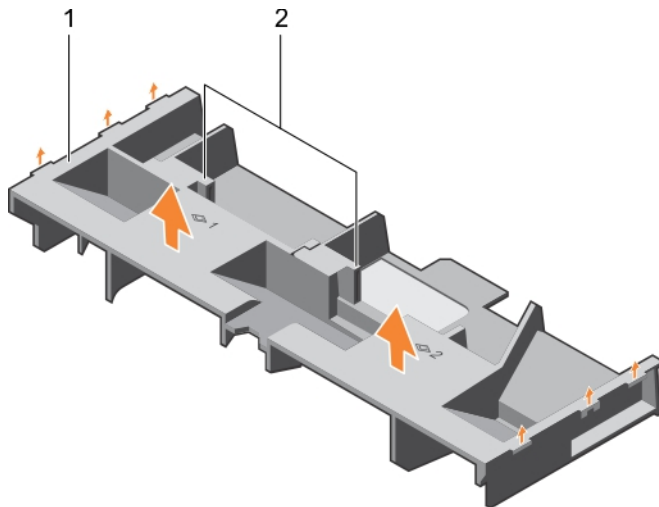

Figure 12. Removing and installing the cooling shroud

1. cooling shroud
2. touch point (2)

#### Next steps

1. Replace the cooling shroud. See [Installing the cooling shroud](#).
2. Follow the procedure listed in [After working inside your system](#).

## Installing the cooling shroud

### Prerequisites

 **CAUTION:** Many repairs may only be done by a certified service technician. You should only perform troubleshooting and simple repairs as authorized in your product documentation, or as directed by the online or telephone service and support team. Damage due to servicing that is not authorized by Dell is not covered by your warranty. Read and follow the safety instructions that came with the product.

1. Ensure that you read the [Safety instructions](#).
2. Route the cables inside the system along the chassis wall and secure the cables using the cable-securing bracket.

### Steps

1. Align the tabs on the cooling shroud with the securing slots on the chassis.
2. Lower the cooling shroud into the chassis until it is firmly seated.

### Next steps

1. Follow the procedure listed in [After working inside your system](#).

## Cooling fans

Your system supports six hot-swappable cooling fans.

 **NOTE:** In the event of a problem with a particular fan, the fan number is referenced by the system management software, allowing you to easily identify and replace the proper fan by noting the fan numbers on the cooling-fan assembly.

## Removing a cooling fan

### Prerequisites

1. Ensure that you read the [Safety instructions](#).
2. Follow the procedure listed in [Before working inside your system](#).

 **CAUTION:** Many repairs may only be done by a certified service technician. You should only perform troubleshooting and simple repairs as authorized in your product documentation, or as directed by the online or telephone service and support team. Damage due to servicing that is not authorized by Dell is not covered by your warranty. Read and follow the safety instructions that came with the product.

 **CAUTION:** The cooling fans are hot-swappable. To maintain proper cooling while the system is on, replace only one fan at a time.

 **NOTE:** The procedure for removing each fan is identical.

### Steps

Press the fan release tab and lift the cooling fan out of the cooling-fan assembly.

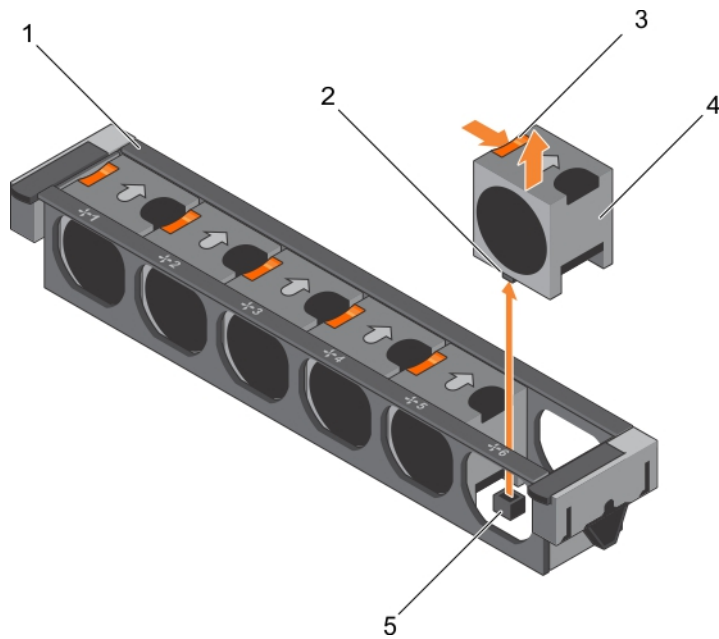

**Figure 13. Removing and installing a cooling fan**

- |  |                              |
|--|------------------------------|
| 1. cooling-fan assembly                      | 2. cooling-fan connector (6) |
| 3. fan release tab (6)                       | 4. cooling fan (6)           |
| 5. cooling-fan connector on system board (6) |                              |

#### Next steps

1. Replace the cooling fan. See [Installing a cooling fan](#).
2. Follow the procedure listed in [After working inside your system](#).

## Installing a cooling fan

#### Prerequisites

1. Ensure that you read the [Safety instructions](#).
2. Follow the procedure listed in [Before working inside your system](#).

**⚠ CAUTION:** Many repairs may only be done by a certified service technician. You should only perform troubleshooting and simple repairs as authorized in your product documentation, or as directed by the online or telephone service and support team. Damage due to servicing that is not authorized by Dell is not covered by your warranty. Read and follow the safety instructions that came with the product.

#### Steps

1. Align the plug at the base of the cooling fan with the connector on the system board.
2. Slide the cooling fan into the securing slots until the tabs lock into place.

#### Next steps

Follow the procedure listed in [After working inside your system](#).

# Cooling-fan assembly

## Removing the cooling-fan assembly

### Prerequisites

1. Ensure that you read the [Safety instructions](#).
2. Follow the procedure listed in [Before working inside your system](#).

**CAUTION:** Many repairs may only be done by a certified service technician. You should only perform troubleshooting and simple repairs as authorized in your product documentation, or as directed by the online or telephone service and support team. Damage due to servicing that is not authorized by Dell is not covered by your warranty. Read and follow the safety instructions that came with the product.

### Steps

1. Unlock the cooling-fan assembly from the chassis by lifting the release levers upward.
2. Lift the cooling-fan assembly out of the chassis.

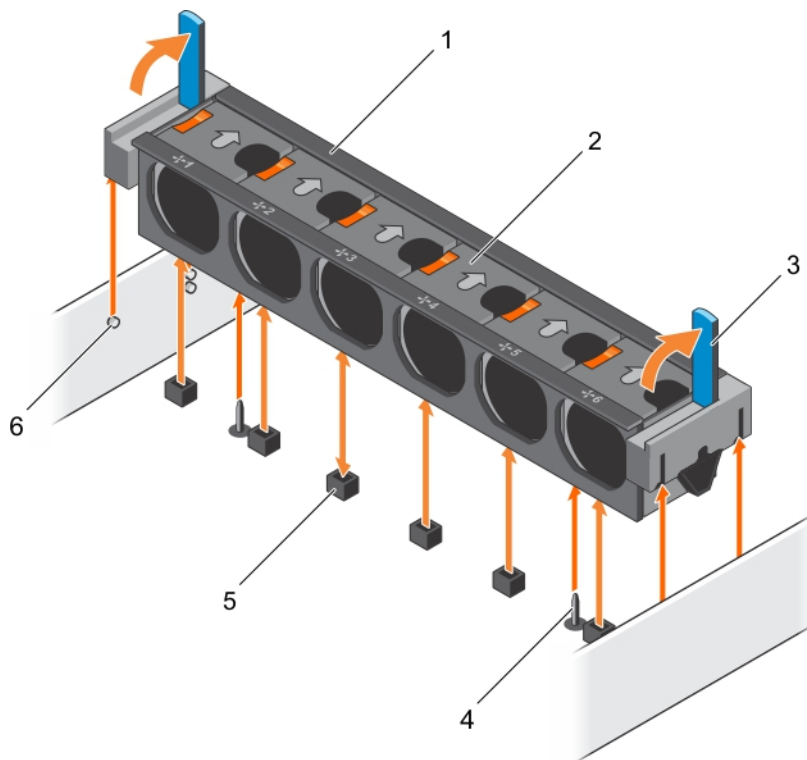

**Figure 14. Removing and installing the cooling-fan assembly**

- |                              |                                      |
|------------------------------|--------------------------------------|
| 1. cooling-fan assembly      | 2. cooling fan (6)                   |
| 3. release lever (2)         | 4. guide pin on the system board (2) |
| 5. cooling-fan connector (6) | 6. guide pin on the chassis (6)      |

### Next steps

1. Replace the cooling-fan assembly. See [Installing the cooling-fan assembly](#).
2. Follow the procedure listed in [After working inside your system](#).

## Installing the cooling-fan assembly

### Prerequisites

 **CAUTION:** Many repairs may only be done by a certified service technician. You should only perform troubleshooting and simple repairs as authorized in your product documentation, or as directed by the online or telephone service and support team. Damage due to servicing that is not authorized by Dell is not covered by your warranty. Read and follow the safety instructions that came with the product.

1. Ensure that you read the [Safety instructions](#).
2. Follow the procedure listed in [Before working inside your system](#).

 **CAUTION:** Ensure that the cables are correctly installed and retained by the cable retention bracket before installing the cooling-fan assembly. Incorrectly installed cables may get damaged.

### Steps

1. Align the cooling-fan assembly slots with the guide pins on the chassis.
2. Slide the cooling-fan assembly into the chassis.
3. Lock the cooling-fan assembly into the chassis by lowering the release levers until firmly seated.

### Next steps

Follow the procedure listed in [After working inside your system](#).

## System memory

Your system supports DDR4 registered DIMMs (RDIMMs), and load reduced DIMMs (LRDIMMs).

 **NOTE:** MT/s indicates DIMM speed in MegaTransfers per second.

Memory bus operating frequency can be 1333 MT/s, 1600 MT/s, 1866 MT/s, or 2133 MT/s depending on the following factors:

- DIMM type (RDIMM or LRDIMM)
- Number of DIMMs populated per channel
- System profile selected (for example, Performance Optimized, Custom, or Dense Configuration Optimized)
- Maximum supported DIMM frequency of the processors

The system contains 24 memory sockets split into two sets of 12 sockets, one set per processor. Each 12-socket set is organized into four channels. In each channel, the release levers of the first socket are marked white, the second socket black, and the third socket green.

 **NOTE:** DIMMs in sockets A1 to A12 are assigned to processor 1 and DIMMs in sockets B1 to B12 are assigned to processor 2.

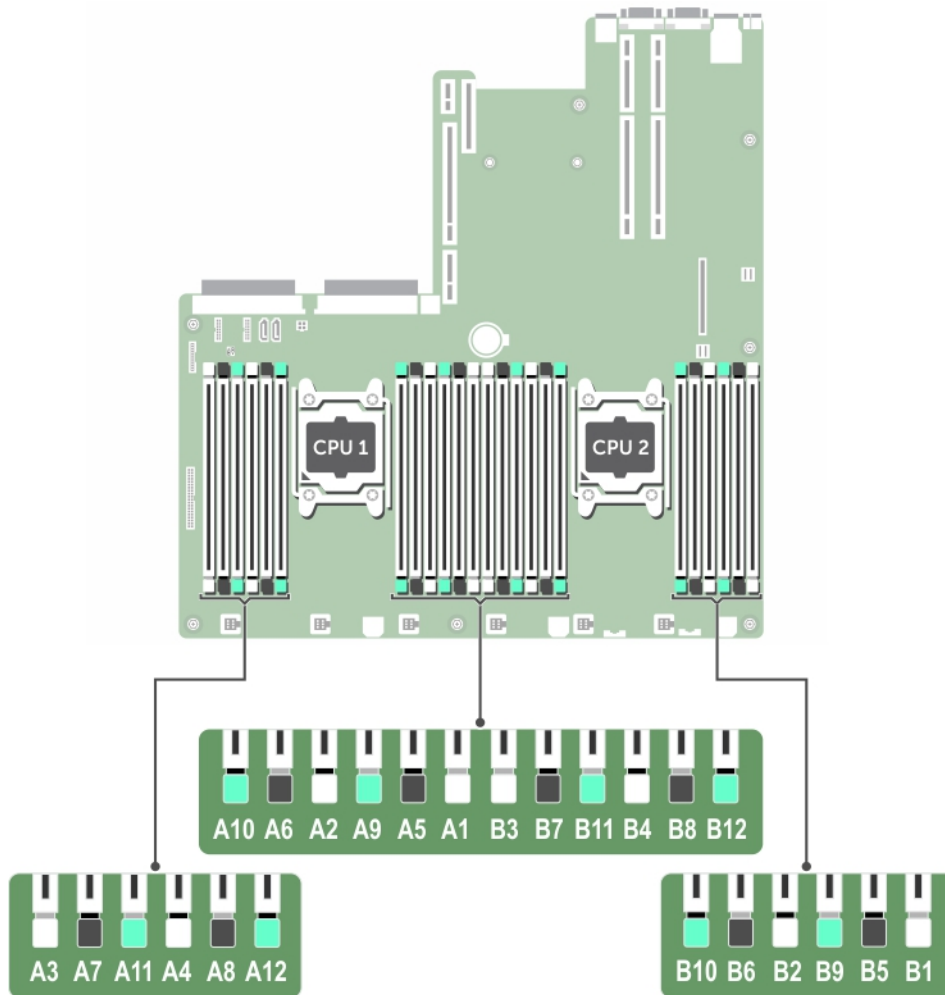

**Figure 15. Memory socket locations**

Memory channels are organized as follows:

- |                    |   |
|--------------------|---|
| <b>Processor 1</b> | channel 0: slots A1, A5, and A9<br>channel 1: slots A2, A6, and A10<br>channel 2: slots A3, A7, and A11<br>channel 3: slots A4, A8, and A12 |
| <b>Processor 2</b> | channel 0: slots B1, B5, and B9<br>channel 1: slots B2, B6, and B10<br>channel 2: slots B3, B7, and B11<br>channel 3: slots B4, B8, and B12 |

## General memory module installation guidelines

This system supports Flexible Memory Configuration, you can configure and run the system in any valid chipset architectural configuration. The following are the recommended guidelines for installing memory modules:

- RDIMMs and LRDIMMs must not be mixed.
- x4 and x8 DRAM based DIMMs can be mixed.
- Up to three dual- or single-rank RDIMMs can be populated per channel.
- Up to three LRDIMMs can be populated per channel regardless of rank count.
- Populate DIMM sockets only if a processor is installed. For single-processor systems, sockets A1 to A12 are available. For dual-processor systems, sockets A1 to A12 and sockets B1 to B12 are available.
- Populate all sockets with white release tabs first, then black, and then green.
- Populate the sockets by highest rank count in the following order — first in sockets with white release levers, then black, and then green. For example, if you want to mix single-rank and dual-rank DIMMs, populate dual-rank DIMMs in the sockets with white release tabs and single-rank DIMMs in the sockets with black release tabs.
- When mixing memory modules with different capacities, populate the sockets with memory modules with highest capacity first. For example, if you want to mix 4 GB and 8 GB DIMMs, populate 8 GB DIMMs in the sockets with white release tabs and 4 GB DIMMs in the sockets with black release tabs.
- In a dual-processor configuration, the memory configuration for each processor should be identical. For example, if you populate socket A1 for processor 1, then populate socket B1 for processor 2, and so on.
- Memory modules of different capacities can be mixed provided other memory population rules are followed (for example, 4 GB and 8 GB memory modules can be mixed).
- Mixing of more than two DIMM capacities in a system is not supported.
- Populate four DIMMs per processor (one DIMM per channel) at a time to maximize performance.

## Sample memory configurations

The following tables show sample memory configurations for one and two processor configurations that follow the appropriate memory guidelines.

**Table 25. Memory configuration**

System capacity (in GB)	DIMM size (in GB)	Number of DIMMs	DIMM rank, organization, and frequency	DIMM slot population
32	16	2	2R, x4, 2133 MT/s,	A1, A2

## Removing memory modules

### Prerequisites

 **CAUTION:** Many repairs may only be done by a certified service technician. You should only perform troubleshooting and simple repairs as authorized in your product documentation, or as directed by the online or telephone service and support team. Damage due to servicing that is not authorized by Dell is not covered by your warranty. Read and follow the safety instructions that came with the product.

1. Ensure that you read the [Safety instructions](#).
2. Follow the procedure listed in [Before working inside your system](#).

3. Remove the cooling shroud.
4. If installed, remove the cooling-fan assembly. For more information, see [Removing the cooling-fan assembly](#).

**WARNING:** The memory modules are hot to touch for some time after the system has been powered down. Allow the memory modules to cool before handling them. Handle the memory modules by the card edges and avoid touching the components or metallic contacts on the memory module.

**CAUTION:** To ensure proper system cooling, you must install memory-module blanks in any memory socket that is not occupied. Remove memory-module blanks only if you intend to install memory modules in those sockets.

#### Steps

1. Locate the appropriate memory module socket.

**CAUTION:** Handle each memory module only by the card edges, making sure not to touch the middle of the memory module or metallic contacts.

2. To release the memory module from the socket, simultaneously press the ejectors on both ends of the memory-module socket.

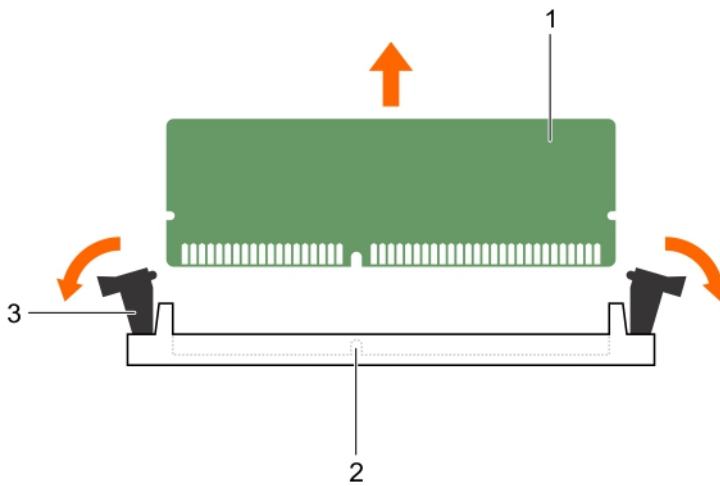

**Figure 16. Removing and installing a memory module**

1. memory-module
2. memory-module socket
3. memory module socket ejector (2)

## Installing memory modules

### Prerequisites

 **CAUTION:** Many repairs may only be done by a certified service technician. You should only perform troubleshooting and simple repairs as authorized in your product documentation, or as directed by the online or telephone service and support team. Damage due to servicing that is not authorized by Dell is not covered by your warranty. Read and follow the safety instructions that came with the product.

1. Ensure that you read the [Safety instructions](#).
2. Follow the procedure listed in [Before working inside your system](#).
3. Remove the cooling shroud.
4. Removing the cooling-fan assembly.

 **WARNING:** The memory modules are hot to touch for some time after the system has been powered down. Allow the memory modules to cool before handling them. Handle the memory modules by the card edges and avoid touching the components or metallic contacts on the memory module.

 **CAUTION:** To ensure proper system cooling, memory-module blanks must be installed in any memory socket that is not occupied. Remove memory-module blanks only if you intend to install memory modules in those sockets.

### Steps

1. Locate the appropriate memory-module socket.

 **CAUTION:** Handle each memory module only by the card edges, making sure not to touch the middle of the memory module or metallic contacts.

2. If a memory module or a memory-module blank is installed in the socket, remove it.

 **NOTE:** Retain the removed memory-module blanks for future use.

 **CAUTION:** To prevent damage to the memory module or the memory-module socket during installation, do not bend or flex the memory module; insert both ends of the memory module simultaneously.

3. Align the edge connector of the memory module with the alignment key of the memory module socket, and insert the memory module in the socket.

 **NOTE:** The memory-module socket has an alignment key that allows you to install the memory module in the socket in only one orientation.

 **CAUTION:** Do not apply pressure at the center of the memory module; apply pressure at both ends of the memory module evenly.

4. Press the memory module with your thumbs until the socket levers firmly click into place.

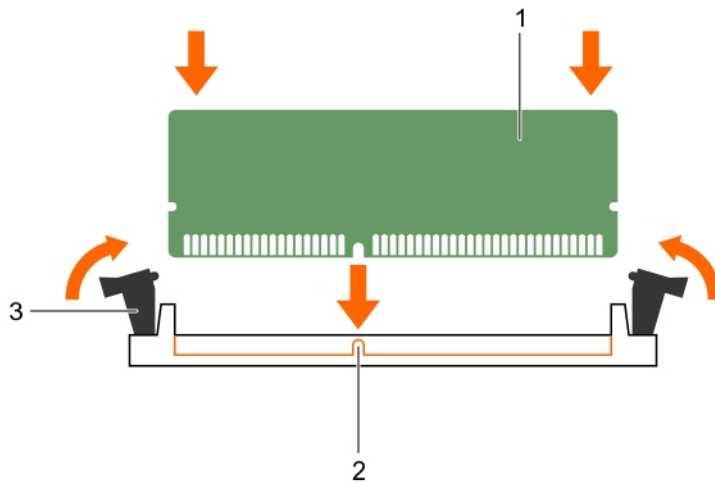

**Figure 17. Installing the memory module**

- |                                     |                  |
|-------------------------------------|------------------|
| 1. memory module                    | 2. alignment key |
| 3. memory-module socket ejector (2) |                  |

When the memory module is properly seated in the socket, the levers on the memory module socket align with the levers on the other sockets that have memory modules installed.

- Repeat steps 1 to 4 of this procedure to install the remaining memory modules.

#### Next steps

- Install the cooling shroud.
- Follow the procedure listed in [After working inside your system](#).
- Press F2 to enter System Setup, and check the **System Memory** setting.  
The system should have already changed the value to reflect the installed memory.
- If the value is incorrect, one or more of the memory modules may not be installed properly. Repeat step 4 through step 5 of this procedure, checking to ensure that the memory modules are firmly seated in their sockets.
- Run the system memory test in the system diagnostics.

## SATADOM

A SATADOM is a disk-on-module (DOM) form factor with an incorporated standard SATA data connection. By default, the SATADOM comes with a power cable installed and is set in a Read/Write position.

The SATADOM uses an onboard SATA controller and does not require an additional controller.

With Nutanix, you can locate the boot device on a separate controller from the data drives, which improves system disk performance.

## Important information about SATADOM

The SATA Disk-On-Motherboard (SATADOM) shipped with XC Series appliances is intended as an appliance boot device.

 **NOTE:** Write intensive activities and processes leveraged by XC appliances, are intended to take place on the SSDs and HDDs and not the boot device.

The hypervisor boot device is not intended for application use.

 **WARNING:** Adding additional write intensive software to the SATADOM boot disk results in heavy wear on the device beyond design specifications resulting in premature hardware failure.

You should not run applications on the hypervisor operating system.

### Examples of write intensive applications

Following are the examples of write intensive applications:

- System Center Agents.
  - System Center Configuration Manager (CCMExec.exe).
  - System Center Operations Manager (MonitoringHost.exe).
- Write-intensive Agents.
- Databases.
- Disk management utilities (third-party disk defragmentation or partitioning tools).
- Additional roles outside of the appliance's intended use (web server, domain controller, RDS, and so on.).
- Client-based Antivirus.
- Run Virtual Machines directly on the SATADOM. Ensure that the Virtual Machines run on Solid State Drives (SSDs) and Hard Disk Drives (HDDs).

## Removing the SATADOM

### Prerequisites

1. Ensure that you read the [Safety instructions](#).
2. Follow the procedure listed in [Before working inside your system](#).

 **CAUTION:** Many repairs may only be done by a certified service technician. You should only perform troubleshooting and simple repairs as authorized in your product documentation, or as directed by the online or telephone service and support team. Damage due to servicing that is not authorized by Dell is not covered by your warranty. Read and follow the safety instructions that came with the product.

### Steps

1. Unplug the power cable from the SATADOM Tape Backup Unit (TBU) power connector.
2. Press the lock release on the SATADOM and pull it up and away from the system.

 **NOTE:** After removing the SATADOM, place it in an anti-static container for reuse, return, or temporary storage.

 **NOTE:** Dell recommends that you do not modify the SATADOM Read/Write default setting.

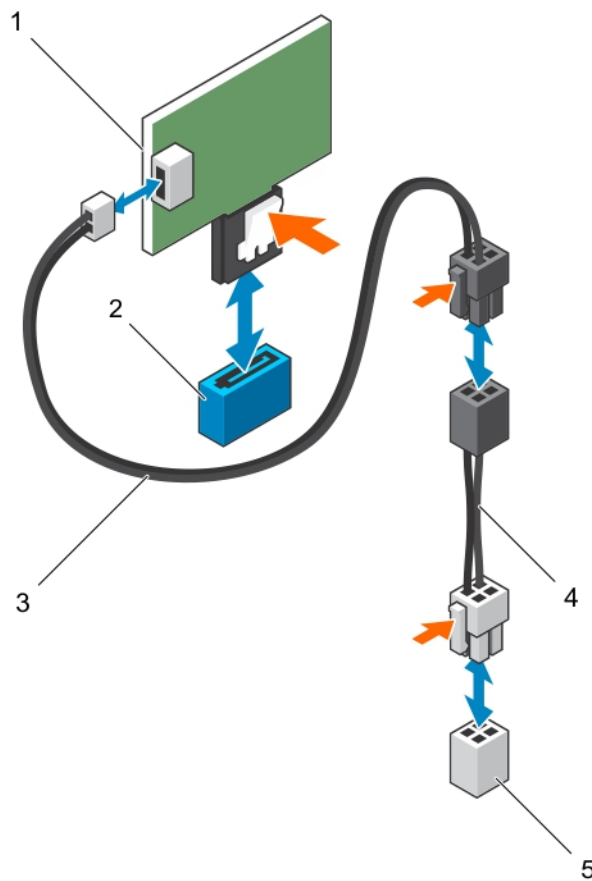

**Figure 18. Removing and installing SATADOM**

- |                                |                   |
|--------------------------------|-------------------|
| 1. SATADOM                     | 2. SATA connector |
| 3. power cable                 | 4. power adapter  |
| 5. SATADOM TBU power connector |                   |

#### Next steps

Follow the procedure listed in [After working inside your system.](#)

## Installing the SATADOM

#### Prerequisites

1. Ensure that you read the [Safety instructions.](#)
2. Follow the procedure listed in [Before working inside your system.](#)

**CAUTION:** Many repairs may only be done by a certified service technician. You should only perform troubleshooting and simple repairs as authorized in your product documentation, or as directed by the online or telephone service and support team. Damage due to servicing that is not authorized by Dell is not covered by your warranty. Read and follow the safety instructions that came with the product.

**NOTE:** Dell recommends that you do not modify the SATADOM Read/Write default setting.

### Steps

1. Press the lock release on the SATADOM and plug the SATADOM into the preferred SATADOM connector on the system board.

 **NOTE:** The preferred SATADOM connector is SATA9 and is indicated in blue. You can also use SATA8 connector that is indicated in black.

2. Plug the power cable into the SATADOM TBU power connector on the system board.

### Next steps

Follow the procedure listed in [After working inside your system](#).

## Heat sinks and processors

Use the following procedure when:

- Installing an additional processor
- Replacing a processor

 **NOTE:** To ensure proper system cooling, you must install a processor blank in any empty processor socket.

### Removing a processor

#### Prerequisites

 **CAUTION:** Many repairs may only be done by a certified service technician. You should only perform troubleshooting and simple repairs as authorized in your product documentation, or as directed by the online or telephone service and support team. Damage due to servicing that is not authorized by Dell is not covered by your warranty. Read and follow the safety instructions that came with the product.

 **NOTE:** To ensure proper system cooling, you must install a processor blank in any empty processor socket.

1. Ensure that you read the [Safety instructions](#).
2. Keep the #2 Phillips screwdriver handy.
3. If you are upgrading your system, download the latest system BIOS version from [Dell.com/support/home](#) and follow the instructions included in the compressed download file to install the update on your system.

 **NOTE:** You can update the system BIOS using the Lifecycle Controller.

4. Follow the procedure listed in [Before working inside your system](#).
5. If installed, remove the cooling fan assembly.
6. If installed, remove the full-length PCIe cards.
7. Remove the cooling shroud.

 **WARNING:** The heat sink and processor are hot to the touch for some time after the system has been powered down. Allow the heat sink and processor to cool before handling them.

 **CAUTION:** Never remove the heat sink from a processor unless you intend to remove the processor. The heat sink is necessary to maintain proper thermal conditions.

### Steps

1. To remove the heat sink:

- a. Loosen one of the screws that secure the heat sink to the system board.  
Wait 30 seconds for the heat sink to loosen from the processor.
- b. Remove the screw diagonally opposite the screw you first removed.
- c. Repeat the procedure for the remaining two screws.
- d. Remove the heat sink.

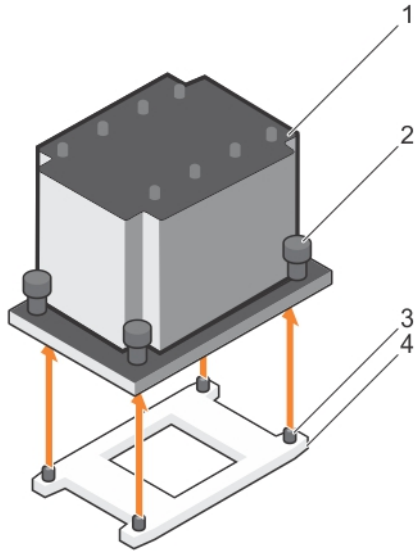

**Figure 19. Removing and installing a processor**

- |                     |                       |
|---------------------|-----------------------|
| 1. heat sink        | 2. captive screws (4) |
| 3. processor socket | 4. slots (4)          |

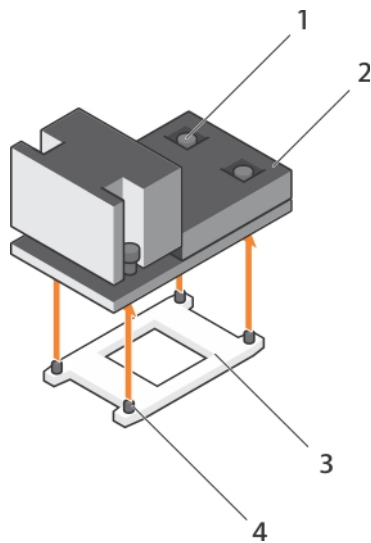

**Figure 20. Removing and installing a processor heat sink**

- |                      |              |
|----------------------|--------------|
| 1. captive screw (4) | 2. heat sink |
| 3. processor socket  | 4. slot (4)  |

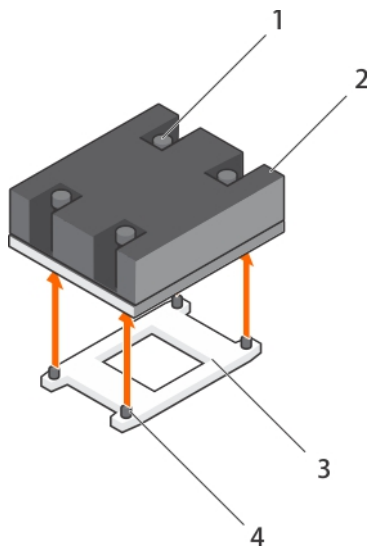

**Figure 21. Removing and installing a processor heat sink**

- |                      |              |
|----------------------|--------------|
| 1. captive screw (4) | 2. heat sink |
| 3. processor socket  | 4. slot (4)  |

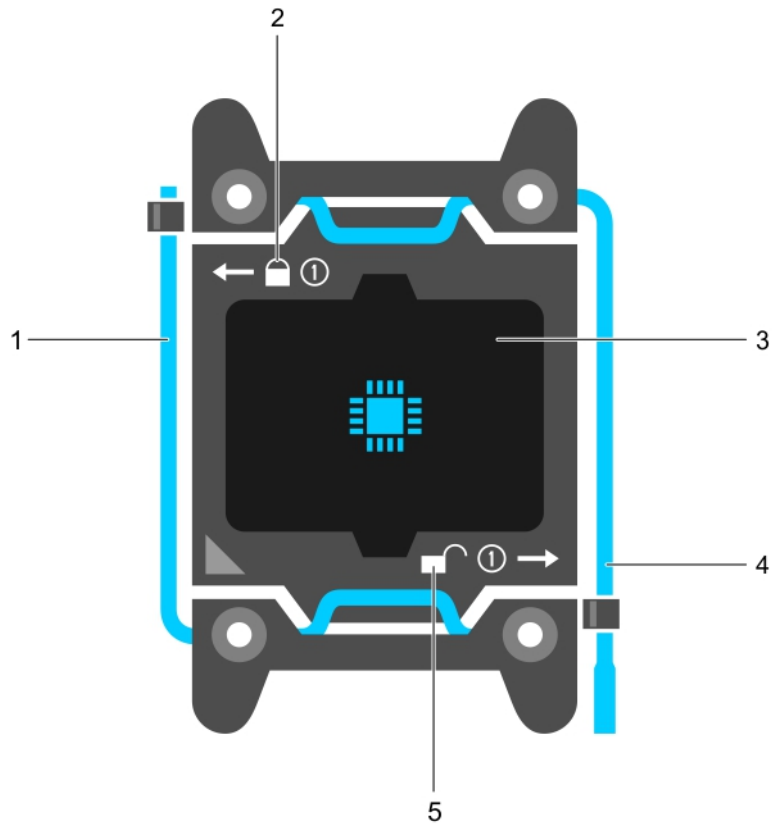

**⚠ CAUTION: The processor is held in its socket under strong pressure. Be aware that the release lever can spring up suddenly if not firmly grasped.**

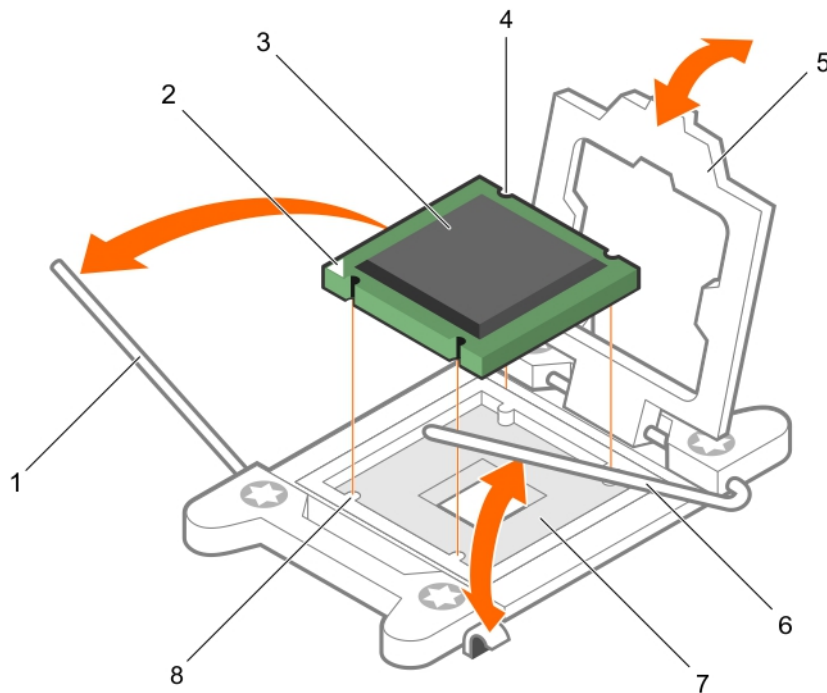

**Figure 22. Processor shield**

- |  |   |
|--|---|
| 1. <i>close first</i> socket release lever | 2. lock icon                              |
| 3. processor                               | 4. <i>open first</i> socket release lever |
| 5. unlock icon                             |   |

**2.** To remove the processor:

- a. Release the *open first* socket-lever near the unlock icon  by pushing the lever down and out from under the tab.
- b. Similarly, release the *close first* socket-release lever near the lock icon  by pushing the lever down and out from under the tab. Lift the lever 90 degrees upward.
- c. Lower the *open first* socket-release lever to lift the processor shield.



**Figure 23. Removing and installing a processor**

- |                                     |                                    |
|-------------------------------------|------------------------------------|
| 1. close first socket-release lever | 2. pin-1 indicator of processor    |
| 3. processor                        | 4. slot (4)                        |
| 5. processor shield                 | 6. open first socket-release lever |
| 7. socket                           | 8. socket keys (4)                 |

- d. Hold the tab on the processor shield and lift the processor shield until the *open first* socket-release lever lifts up.

**CAUTION:** The socket pins are fragile and can be permanently damaged. Be careful not to bend the pins in the socket when removing the processor out of the socket.

- e. Lift the processor out of the socket and leave the *open first* socket-release lever up.

**NOTE:** If you are permanently removing the processor, you must install a socket protective cap in the vacant socket to protect the socket pins and keep the socket free of dust.

**NOTE:** After removing the processor, place it in an anti-static container for reuse, return, or temporary storage. Do not touch the bottom of the processor. Touch only the side edges of the processor.

#### Next steps

1. Replace the heat sinks and processors. See [Installing a processor](#).
2. Follow the procedure listed in [After working inside your system](#).

## Installing a processor

### Prerequisites

 **CAUTION:** Many repairs may only be done by a certified service technician. You should only perform troubleshooting and simple repairs as authorized in your product documentation, or as directed by the online or telephone service and support team. Damage due to servicing that is not authorized by Dell is not covered by your warranty. Read and follow the safety instructions that came with the product.

1. Ensure that you read the [Safety instructions](#).
2. Keep the #2 Phillips screwdriver handy.
3. If you are upgrading your system, download the latest system BIOS version from [Dell.com/support/home](#) and follow the instructions included in the compressed download file to install the update on your system.

 **NOTE:** You can update the system BIOS using the Lifecycle Controller.



4. Follow the procedure listed in [Before working inside your system](#).
5. If installed, remove the cooling fan assembly.
6. If installed, remove the full-length PCIe card.
7. Remove the cooling shroud.

 **WARNING:** The heat sink and processor are hot to the touch for some time after the system has been powered down. Allow the heat sink and processor to cool before handling them.

 **CAUTION:** Never remove the heat sink from a processor unless you intend to remove the processor. The heat sink is necessary to maintain proper thermal conditions.

 **NOTE:** If you are installing a single processor, it must be installed in socket CPU1.

### Steps

1. Remove the heat sink.
2. Unpack the new processor.  
If the processor has previously been used in a system, remove any remaining thermal grease from the processor using a lint-free cloth.
3. Locate the processor socket.
4. If applicable, remove the socket protective cap.
5. Release the *open first* socket-release lever near the unlock icon  by pushing the lever down and out from under the tab.
6. Similarly, release the *close first* socket-release lever near the lock icon  by pushing the lever down and out from under the tab. Lift the lever 90 degrees upward.
7. Hold the tab near the lock symbol on the processor shield and lift it up and out of the way.
8. To install the processor in the socket:

 **CAUTION:** Positioning the processor incorrectly can permanently damage the system board or the processor. Be careful not to bend the pins in the socket.



 **CAUTION:** While removing or reinstalling the processor, wipe your hands of any contaminants. Contaminants on the processor pins such as thermal grease or oil can damage the processor.

- a. Align the processor with the socket keys.

**△ CAUTION: Do not use force to seat the processor. When the processor is positioned correctly, it engages easily into the socket.**

- b. Align the pin-1 indicator of the processor with the triangle on the socket.
- c. Place the processor on the socket such that the slots on the processor align with the socket keys.

**△ CAUTION: Do not use force to seat the processor. When the processor is positioned correctly, it engages easily into the socket.**

- d. Close the processor shield.
  - e. Lower the *close first* socket-release lever near the lock icon  and push it under the tab to lock it.
  - f. Similarly, lower the *open first* socket-release lever near the unlock icon  and push it under the tab to lock it.
9. To install the heat sink:
- a. If applicable, remove the existing thermal grease from the heat sink using a clean lint-free cloth.
  - b. Apply thermal grease on the top of the processor. Use the thermal-grease syringe included with your processor kit to apply the grease in a thin spiral on the top of the processor as shown in the figure.

**△ CAUTION: Applying too much thermal grease can result in excess grease coming in contact with and contaminating the processor socket.**

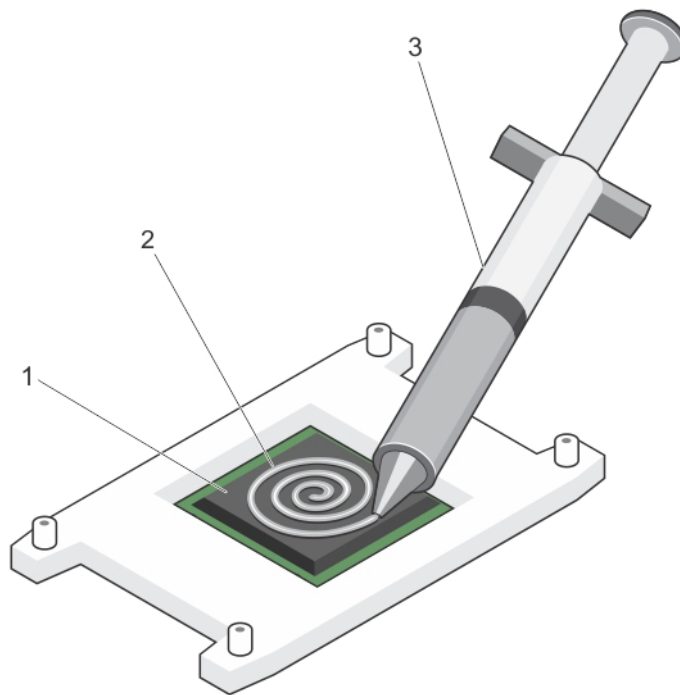

**Figure 24. Applying thermal grease on the top of the processor**

1. processor
2. thermal grease
3. thermal-grease syringe

-  **NOTE:** The thermal-grease is intended for one-time use only. Dispose of the syringe after you use it.
- c. Place the heat sink onto the processor.
- d. Tighten the four screws to secure the heat sink to the system board.

 **NOTE:** Tighten the screws diagonally opposite to each other. Do not over-tighten the heat sink retention screws when installing the heat sink. To prevent over-tightening, tighten the retention screw until resistance is felt, and stop once the screw is seated. The screw tension should be no more than 6 in-lb (6.9 kg-cm).

### Next steps

1. Install the cooling shroud.
2. If applicable, install the PCIe card.
3. If applicable, install the cooling fan assembly.
4. Follow the procedure listed in [After working inside your system](#).
5. While booting, press F2 to enter the System Setup and check that the processor information matches the new system configuration.
6. Run the system diagnostics to verify that the new processor operates correctly.

## PCIe card holder

### Removing the PCIe card holder

#### Prerequisites

1. Ensure that you read the [Safety instructions](#).
2. Follow the procedure listed in [Before working inside your system](#).
3. If installed, remove the full-length PCIe card.

 **CAUTION:** Many repairs may only be done by a certified service technician. You should only perform troubleshooting and simple repairs as authorized in your product documentation, or as directed by the online or telephone service and support team. Damage due to servicing that is not authorized by Dell is not covered by your warranty. Read and follow the safety instructions that came with the product.

 **CAUTION:** Do not use your system without the PCIe card holder installed. The PCIe card holder is necessary to ensure proper system cooling.

#### Steps

1. Press the release tab and slide the card holder toward the back of the chassis to release the PCIe card holder from the chassis.
2. Lift the PCIe card holder out of the chassis.

 **NOTE:** To ensure proper system cooling, you must replace the PCIe card holder.

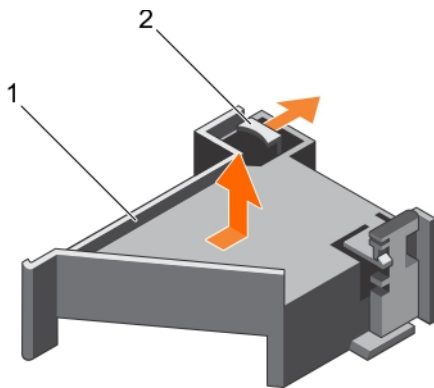

**Figure 25. Removing and installing the PCIe card holder**

1. PCIe card holder
2. release tab

#### Next steps

1. Replace the PCIe card holder. See [Installing the PCIe card holder](#).
2. Follow the procedure listed in [After working inside your system](#).

## Installing the PCIe card holder

#### Prerequisites

1. Ensure that you read the [Safety instructions](#).
2. Follow the procedure listed in [Before working inside your system](#).

**⚠ CAUTION:** Many repairs may only be done by a certified service technician. You should only perform troubleshooting and simple repairs as authorized in your product documentation, or as directed by the online or telephone service and support team. Damage due to servicing that is not authorized by Dell is not covered by your warranty. Read and follow the safety instructions that came with the product.

**⚠ CAUTION:** Do not use your system without the PCIe card holder installed. The PCIe card holder is necessary to ensure proper system cooling.

#### Steps

1. Align the PCIe card holder with the notches and tabs on the power supply unit cage.
2. Press the release tab and slide PCIe card holder toward the front of the chassis until firmly seated.

#### Next steps

1. If applicable, replace the full-length PCIe card.
2. Follow the procedure listed in [After working inside your system](#).

## Opening and closing the PCIe card holder latch

#### Prerequisites

1. Ensure that you read the [Safety instructions](#).
2. Follow the procedure listed in [Before working inside your system](#).

**CAUTION:** Many repairs may only be done by a certified service technician. You should only perform troubleshooting and simple repairs as authorized in your product documentation, or as directed by the online or telephone service and support team. Damage due to servicing that is not authorized by Dell is not covered by your warranty. Read and follow the safety instructions that came with the product.

#### Steps

1. To open the PCIe card holder latch, press the release tab.
2. To close the PCIe card holder latch, rotate the latch clockwise until it locks.

**NOTE:** Before installing a full-length PCIe card, the PCIe card holder latch must be closed. When the full-length PCIe card is installed, open the PCIe card holder latch. Before removing the full-length PCIe card, you must close the PCIe card holder latch.

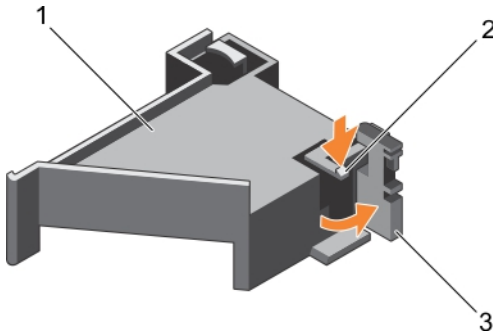

**Figure 26. Opening and closing the PCIe card holder latch**

- |                     |                |
|---------------------|----------------|
| 1. PCIe card holder | 2. release tab |
| 3. PCIe card holder |                |

#### Next steps

Follow the procedure listed in [After working inside your system](#).

## Cable retention bracket

### Removing the cable retention bracket

#### Prerequisites

1. Ensure that you read the [Safety instructions](#).
2. Follow the procedure listed in [Before working inside your system](#).
3. Remove the cooling shroud.
4. Remove the PCIe card holder.
5. Remove all cables routed through the cable retention bracket.

**CAUTION:** Many repairs may only be done by a certified service technician. You should only perform troubleshooting and simple repairs as authorized in your product documentation, or as directed by the online or telephone service and support team. Damage due to servicing that is not authorized by Dell is not covered by your warranty. Read and follow the safety instructions that came with the product.

### Steps

1. Pull the tab to release it from the notch and slide the cable retention bracket toward the front of the chassis to release it from the chassis.
2. Lift the cable retention bracket out of the chassis.

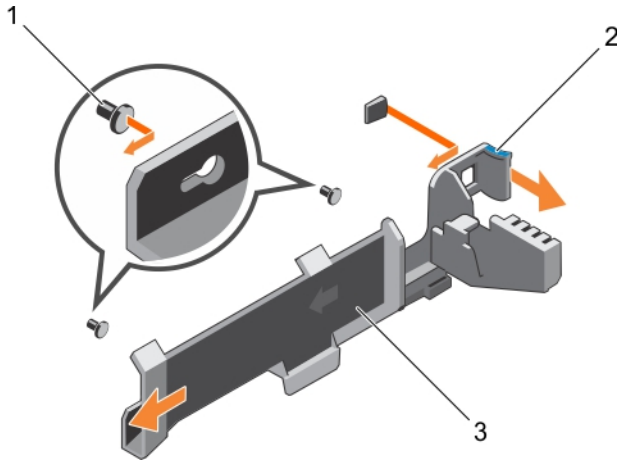

Figure 27. Removing and installing the cable retention bracket

1. alignment pin (2)
2. tab
3. cable retention bracket

### Next steps

1. Replace the cable retention bracket. See [Installing the cable retention bracket](#).
2. Follow the procedure listed in [After working inside your system](#).

## Installing the cable retention bracket

### Prerequisites

1. Ensure that you read the [Safety instructions](#).
2. Follow the procedure listed in [Before working inside your system](#).
3. Remove the cooling shroud.
4. Remove the PCIe card holder.

**△ CAUTION:** Many repairs may only be done by a certified service technician. You should only perform troubleshooting and simple repairs as authorized in your product documentation, or as directed by the online or telephone service and support team. Damage due to servicing that is not authorized by Dell is not covered by your warranty. Read and follow the safety instructions that came with the product.

### Steps

1. Align the cable retention bracket with the alignment pins on the chassis.
2. Slide the cable retention bracket along the chassis wall until the tab clicks and locks the slots.
3. Place all cables to be routed in the cable retention bracket.

### Next steps

1. Install the PCIe card holder.

2. Install the cooling shroud.
3. Follow the procedure listed in [After working inside your system](#).

## Integrated storage controller card

Your system includes a dedicated expansion-card slot on the system board for an integrated controller card. The integrated storage controller card provides the integrated storage subsystem for your system's internal hard drives. The controller supports SAS and SATA hard drives as supported by the version of the storage controller included with your system.

### Removing the integrated storage controller card

#### Prerequisites

1. Ensure that you read the [Safety instructions](#).
2. Follow the procedure listed in [Before working inside your system](#).
3. Remove the cooling shroud.
4. Remove the expansion-card riser 1.
5. Keep the #2 Phillips screwdriver handy.

 **CAUTION: Many repairs may only be done by a certified service technician. You should only perform troubleshooting and simple repairs as authorized in your product documentation, or as directed by the online or telephone service and support team. Damage due to servicing that is not authorized by Dell is not covered by your warranty. Read and follow the safety instructions that came with the product.**

#### Steps

1. Loosen the screws that secure the integrated storage controller cable to the integrated storage-controller card connector on the system board.
2. Lift the integrated storage controller cable out.
3. Lift one end of the card and angle it to disengage the card from the integrated storage-controller card holder on system board.
4. Lift the card out of the chassis.

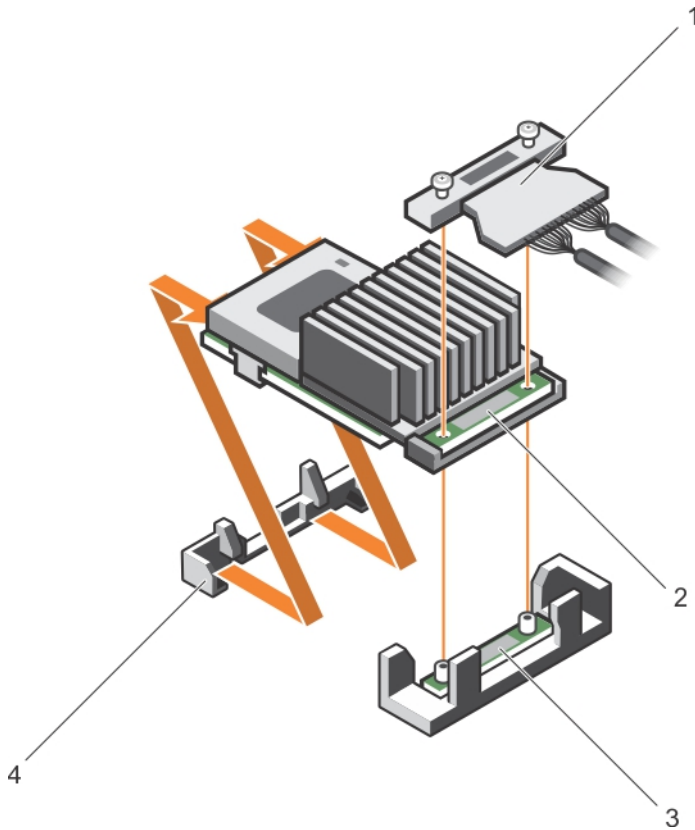

**Figure 28. Removing and installing the integrated storage controller card**

- |   |  |
|---|--|
| 1. integrated storage controller cable                              | 2. integrated storage controller card        |
| 3. integrated storage-controller card connector on the system board | 4. integrated storage controller card holder |

#### Next steps

1. Replace the expansion-card riser 1.
2. Replace the cooling shroud.
3. Follow the procedure listed in [After working inside your system.](#)

### Installing the integrated storage controller card

#### Prerequisites

1. Ensure that you read the [Safety instructions.](#)
2. Follow the procedure listed in [Before working inside your system.](#)
3. Remove the cooling shroud.
4. Remove the expansion-card riser 1.
5. Keep the #2 Phillips screwdriver handy.

 **CAUTION:** Many repairs may only be done by a certified service technician. You should only perform troubleshooting and simple repairs as authorized in your product documentation, or as directed by the online or telephone service and support team. Damage due to servicing that is not authorized by Dell is not covered by your warranty. Read and follow the safety instructions that came with the product.

**Steps**

1. Align the end of the integrated storage-controller card opposite the connector with the integrated storage-controller card holder.
2. Lower the connector side of the integrated storage-controller card into the integrated storage-controller card connector on the system board.  
Ensure that the tabs on the system board align with the screw holes on the integrated storage-controller card.
3. Align the screws on the integrated storage-controller card cable with the screw holes on the connector.
4. Tighten the screws to secure the integrated storage-controller card cable with the integrated storage-controller card connector on the system board.

**Next steps**

1. Replace the expansion-card riser 1.
2. Replace the cooling shroud.
3. Follow the procedure listed in [After working inside your system](#).

## Expansion cards and expansion-card risers

 **NOTE:** A missing or an unsupported expansion-card riser logs an SEL event. It does not prevent your system from powering on and no BIOS POST message or F1/F2 pause is displayed.

### Expansion card installation guidelines

Depending on your system configuration:

The following PCI Express generation 3 expansion cards are supported:

**Table 26. Supported expansion cards**

Riser	PCIe slot	Processor connection	Height	Length	Link width	Slot width
2	5	Processor 1	Full Height	Full Length	x8	x16
3 (default)	6	Processor 1	Full Height	Full Length	x8	x16
3 (alternate)	6	Processor 1	Full Height	Full Length	x16	x16
3 (default)	7	Processor 1	Full Height	Full Length	x8	x16

 **NOTE:** The expansion-card slots are not hot-swappable.

The following table provides guidelines for installing expansion cards to ensure proper cooling and mechanical fit. The expansion cards with the highest priority must be installed first using the slot priority indicated. Install all other expansion cards in card priority and slot priority order.

Table 27. Expansion card installation order

Card priority	Card type	Slot priority	Max allowed
2	10 Gb NICs (full height)	4,6,5	3
4	Integrated RAID	integrated slot	1
5	NDC	integrated slot	3

## Removing an expansion card from expansion-card riser 2 or 3

### Prerequisites

 **CAUTION:** Many repairs may only be done by a certified service technician. You should only perform troubleshooting and simple repairs as authorized in your product documentation, or as directed by the online or telephone service and support team. Damage due to servicing that is not authorized by Dell is not covered by your warranty. Read and follow the safety instructions that came with the product.

1. Ensure that you read the [Safety instructions](#).
2. Follow the procedure listed in [Before working inside your system](#).
3. When removing a card from Riser 3, ensure that the PCIe holder latch is closed.

 **NOTE:** The procedure for installing and removing a full length PCIe card is similar to the procedure for removing and installing a GPU card. For more information, see [Removing a GPU card](#) and [Installing a GPU card](#).

### Steps

1. Disconnect any cables connected to the expansion card.
2. Lift the expansion-card latch out of the slot.
3. Hold the expansion card by its edges, and remove it from the expansion-card connector.
4. If you are removing the card permanently, install a metal filler bracket over the empty expansion slot opening and close the expansion-card latch.
5. Replace the expansion-card latch into the slot.
6. Close the expansion-card locking tabs.

 **NOTE:** You must install a filler bracket over an empty expansion slot to maintain Federal Communications Commission (FCC) certification of the system. The brackets also keep dust and dirt out of the system and aid in proper cooling and airflow inside the system.

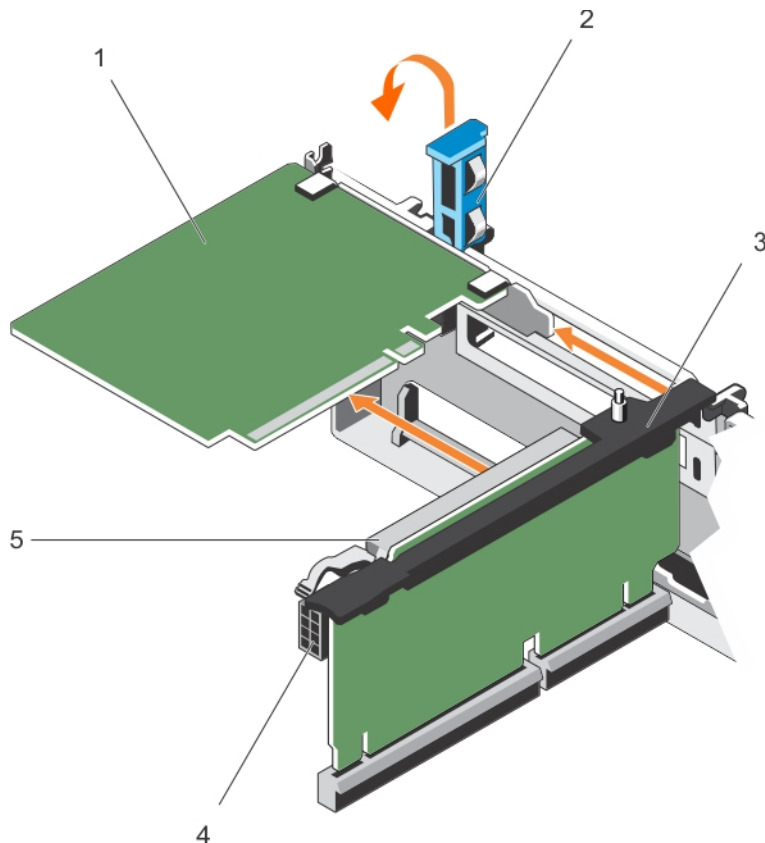

**Figure 29. Removing and installing an expansion card from expansion-card riser 2 or 3**

- |                             |                         |
|-----------------------------|-------------------------|
| 1. expansion card           | 2. expansion-card latch |
| 3. expansion-card riser     | 4. power connector      |
| 5. expansion-card connector |                         |

#### Next steps

Follow the procedure listed in [After working inside your system.](#)

## Installing an expansion card into the expansion-card riser 2 or 3

#### Prerequisites

1. Ensure that you read the [Safety instructions.](#)
2. Follow the procedure listed in [Before working inside your system.](#)

**CAUTION:** Many repairs may only be done by a certified service technician. You should only perform troubleshooting and simple repairs as authorized in your product documentation, or as directed by the online or telephone service and support team. Damage due to servicing that is not authorized by Dell is not covered by your warranty. Read and follow the safety instructions that came with the product.

#### Steps

1. Unpack the expansion card and prepare it for installation.

For instructions, see the documentation accompanying the card.

2. Lift the expansion-card latch and remove the filler bracket.
3. Holding the card by its edges, position the card so that the connector on the expansion card aligns with the expansion-card connector on the riser.
4. Insert the card-edge connector firmly into the expansion-card connector until the card is fully seated.
5. Press the touch points to open the expansion-card locking tabs.
6. Replace the expansion-card latch.
7. If applicable, connect the cables to the expansion card.

#### Next steps

1. Follow the procedure listed in [After working inside your system](#).
2. Install any device drivers required for the card as described in the documentation for the card.

## Removing expansion-card risers

#### Prerequisites



**CAUTION:** Many repairs may only be done by a certified service technician. You should only perform troubleshooting and simple repairs as authorized in your product documentation, or as directed by the online or telephone service and support team. Damage due to servicing that is not authorized by Dell is not covered by your warranty. Read and follow the safety instructions that came with the product.

1. Ensure that you read the [Safety instructions](#).
2. Follow the procedure listed in [Before working inside your system](#).
3. If installed, remove any expansion card installed on riser 2 and 3.

#### Steps

Holding the slots on the expansion-card riser, lift the riser from the riser connector on the system board.



**NOTE:** To remove expansion-card risers 2 and 3, hold the edges of the expansion-card riser.



**NOTE:** To ensure proper system cooling, the riser 1 blank must be installed in the riser 1 slot. Remove the riser 1 blank only if you are installing riser 1.

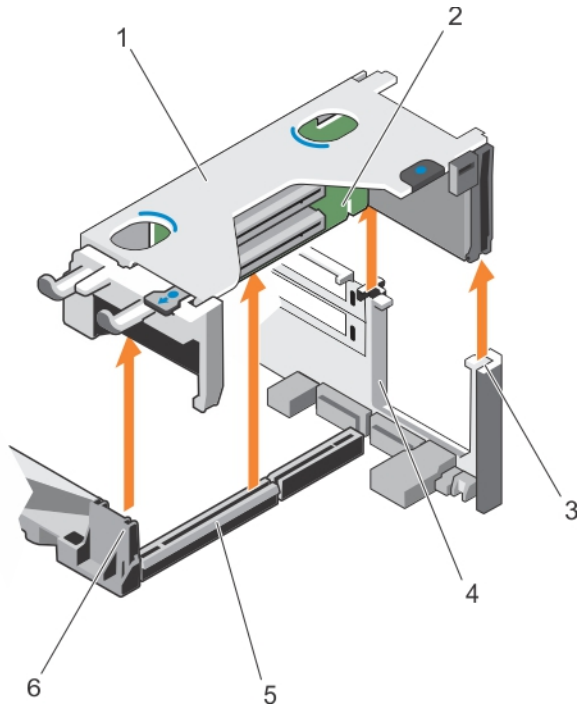

**Figure 30. Removing and installing the expansion card riser 1**

- |                                     |                            |
|-------------------------------------|----------------------------|
| 1. expansion-card riser 1 cage      | 2. expansion-card riser 1  |
| 3. riser guide-back (right)         | 4. riser guide-back (left) |
| 5. expansion-card riser 1 connector | 6. riser guide-front       |

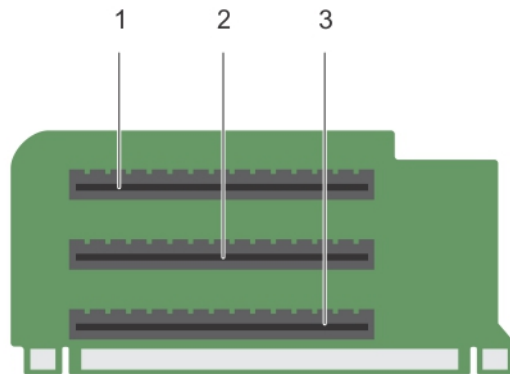

**Figure 31. Identifying connectors on the expansion card riser 1**

- |                          |                          |
|--------------------------|--------------------------|
| 1. expansion-card slot 1 | 2. expansion-card slot 2 |
|--------------------------|--------------------------|

3. expansion-card slot 3

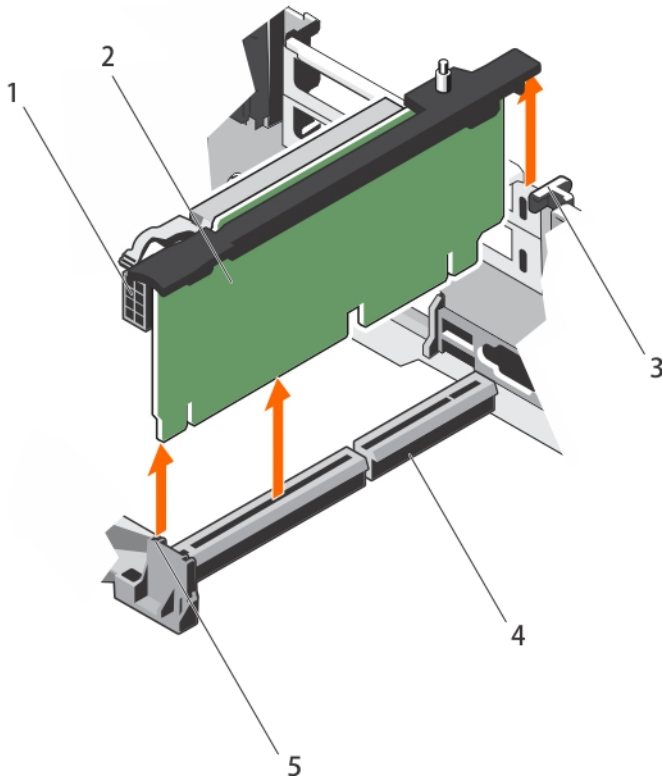

**Figure 32. Removing and installing the expansion card riser 2**

- |                      |                                     |
|----------------------|-------------------------------------|
| 1. power connector   | 2. expansion-card riser 2           |
| 3. riser guide-back  | 4. expansion-card riser 2 connector |
| 5. riser guide-front |                                     |

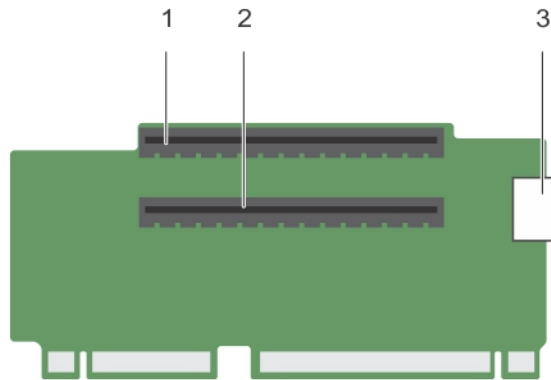

**Figure 33. Identifying connectors on the expansion card riser 2**

- 1. expansion-card slot 4
- 2. expansion-card slot 5
- 3. power connector

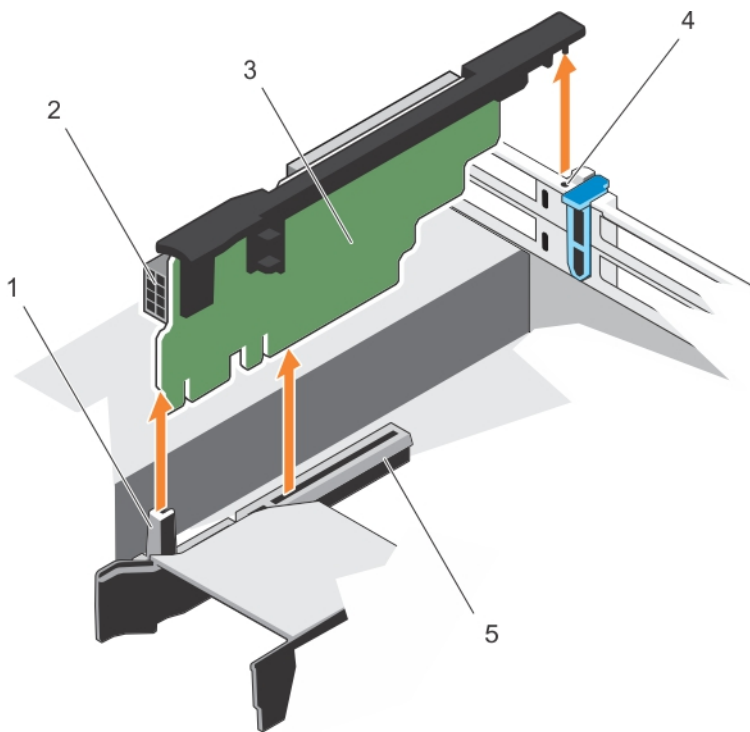

**Figure 34. Removing and installing the expansion card riser 3**

- 1. riser guide-front
- 2. power connector

- 3. expansion-card riser 3
- 4. riser guide-back
- 5. expansion-card riser 3 connector

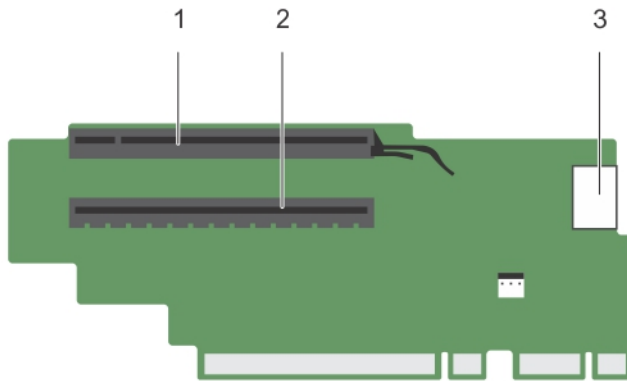

**Figure 35. Identifying connectors on the expansion card riser 3 (default)**

- 1. expansion-card slot 6
- 2. expansion-card slot 7
- 3. power connector

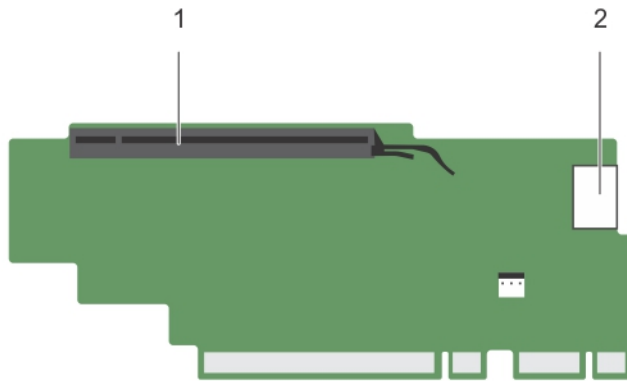

**Figure 36. Identifying connectors on the expansion card riser 3 (alternate)**

- 1. expansion-card slot 6
- 2. power connector

**Next steps**

- 1. If applicable, remove or install an expansion card on the riser.
- 2. If applicable, replace the expansion-card riser.
- 3. Follow the procedure listed in [After working inside your system.](#)

## Installing expansion-card risers

### Prerequisites

1. Ensure that you read the [Safety instructions](#).
2. Follow the procedure listed in [Before working inside your system](#).

 **CAUTION:** Many repairs may only be done by a certified service technician. You should only perform troubleshooting and simple repairs as authorized in your product documentation, or as directed by the online or telephone service and support team. Damage due to servicing that is not authorized by Dell is not covered by your warranty. Read and follow the safety instructions that came with the product.

### Steps

1. Align the expansion-card riser with the connectors and the riser guides on the system board.
2. Lower the expansion-card riser into place until the expansion-card riser is fully seated in the connector.

### Next steps

1. Install the expansion cards into the expansion-card risers 2 or 3.
2. Follow the procedure listed in [After working inside your system](#).
3. Install any device drivers required for the card as described in the documentation for the card.

## Internal dual SD module

### Removing an internal SD card

#### Prerequisites

1. Ensure that you read the [Safety instructions](#).
2. Follow the procedure listed in [Before working inside your system](#).

 **CAUTION:** Many repairs may only be done by a certified service technician. You should only perform troubleshooting and simple repairs as authorized in your product documentation, or as directed by the online or telephone service and support team. Damage due to servicing that is not authorized by Dell is not covered by your warranty. Read and follow the safety instructions that came with the product.

Locate the SD card slot on the internal dual SD module and press the card to release it from the slot.

#### Steps

1. Remove the PCIe Card.
2. Remove riser 3.
3. Locate the SD card slot on the internal dual SD module and press the card to release it from the slot.

#### Next steps

Follow the procedure listed in [After working inside your system](#).

## Installing an internal SD card

### Prerequisites

1. Ensure that you read the [Safety instructions](#).
2. Follow the procedure listed in [Before working inside your system](#).
3. If installed, remove the cooling shroud.

 **CAUTION:** Many repairs may only be done by a certified service technician. You should only perform troubleshooting and simple repairs as authorized in your product documentation, or as directed by the online or telephone service and support team. Damage due to servicing that is not authorized by Dell is not covered by your warranty. Read and follow the safety instructions that came with the product.

 **NOTE:** To use an SD card with your system, ensure that the **Internal SD Card Port** is enabled in the System Setup.

### Steps

1. Locate the SD card connector on the internal dual SD module. Orient the SD card appropriately and insert the contact-pin end of the card into the slot.

 **NOTE:** The slot is keyed to ensure of correct card insertion correct insertion of the card.

2. Press the card into the card slot to lock it into place.

### Next steps

Follow the procedure listed in [After working inside your system](#).

1. If removed, replace the cooling shroud.
2. Follow the procedure listed in [After working inside your system](#).

## Removing the internal dual SD module

### Prerequisites

 **CAUTION:** Many repairs may only be done by a certified service technician. You should only perform troubleshooting and simple repairs as authorized in your product documentation, or as directed by the online or telephone service and support team. Damage due to servicing that is not authorized by Dell is not covered by your warranty. Read and follow the safety instructions that came with the product.

1. Ensure that you read the [Safety instructions](#).
2. Follow the procedure listed in [Before working inside your system](#).

### Steps

1. Locate the internal dual SD module on the system board.
2. If installed, remove the SD cards.
3. Hold the plastic pull tab and pull the dual SD module out of the system board.

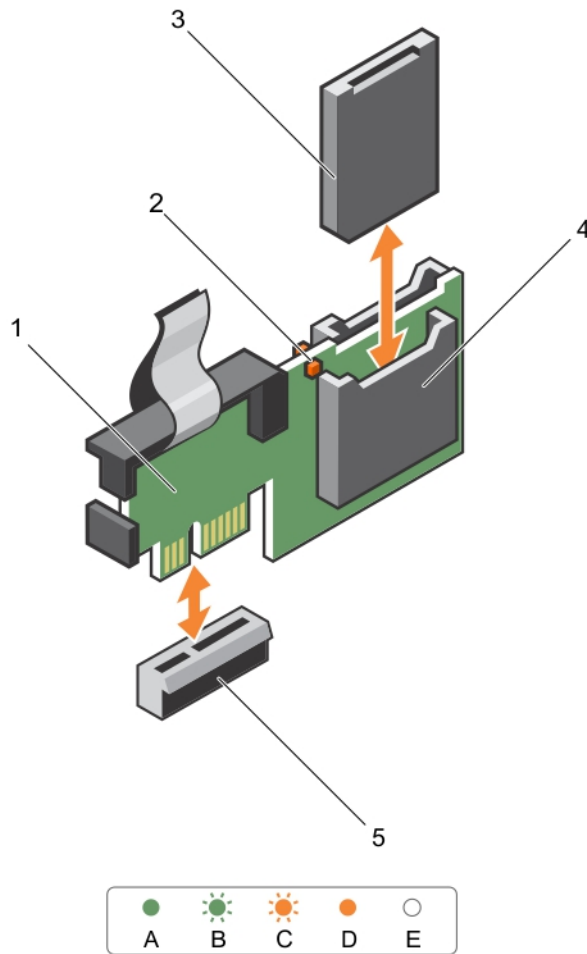

**Figure 37. Removing and installing the Internal Dual SD Module (IDSDM)**

- |                            |                             |
|----------------------------|-----------------------------|
| 1. Internal Dual SD module | 2. LED status indicator (2) |
| 3. SD card                 | 4. SD card slot 2           |
| 5. SD card slot 1          | 6. IDSDM connector          |

**Table 28. IDSDM indicator codes**

Convention	IDSDM indicator code	Description
A	Green	Indicates that the card is online
B	Flashing green	Indicates rebuild or activity
C	Flashing amber	Indicates card mismatch or that the card has failed
D	Amber	Indicates that the card is offline, has failed, or is write protected

Convention	IDSDM indicator code	Description
E	Not lit	Indicates that the card is missing or booting

### Next steps

Follow the procedure listed in [After working inside your system](#).

## Installing the internal dual SD module

### Prerequisites

 **CAUTION:** Many repairs may only be done by a certified service technician. You should only perform troubleshooting and simple repairs as authorized in your product documentation, or as directed by the online or telephone service and support team. Damage due to servicing that is not authorized by Dell is not covered by your warranty. Read and follow the safety instructions that came with the product.

1. Ensure that you read the [Safety instructions](#).
2. Follow the procedure listed in [Before working inside your system](#).

### Steps

1. Locate the IDSDM connector on the system board. To locate the IDSDM connector, see [System board connectors](#).
2. Align the connectors on the system board and the dual SD module.
3. Push the dual SD module until it is firmly seated on the system board.

### Next steps

1. Install the SD vFlash media card(s).
  -  **NOTE:** Temporarily label each SD card with its corresponding slot before removal. Replace the SD card(s) into the same slots.
2. Follow the procedure listed in [After working inside your system](#).

## Network daughter card

### Removing the network daughter card

#### Prerequisites

1. Ensure that you read the [Safety instructions](#).
2. Follow the procedure listed in [Before working inside your system](#).
3. If installed, remove expansion card(s) from the expansion-card riser 2.
4. Keep the #1 Phillips screwdriver handy.

 **CAUTION:** Many repairs may only be done by a certified service technician. You should only perform troubleshooting and simple repairs as authorized in your product documentation, or as directed by the online or telephone service and support team. Damage due to servicing that is not authorized by Dell is not covered by your warranty. Read and follow the safety instructions that came with the product.

### Steps

1. Using a #1 Phillips screwdriver, loosen the captive screws that secure the network daughter card to the system board.
2. Hold the network daughter card by the edges on either side of the touch point and lift the card to remove it from the connector on the system board.
3. Slide the network daughter card away from the back of the system until the Ethernet connectors are clear of the slot in the back panel.
4. Lift the network daughter card out of the chassis.

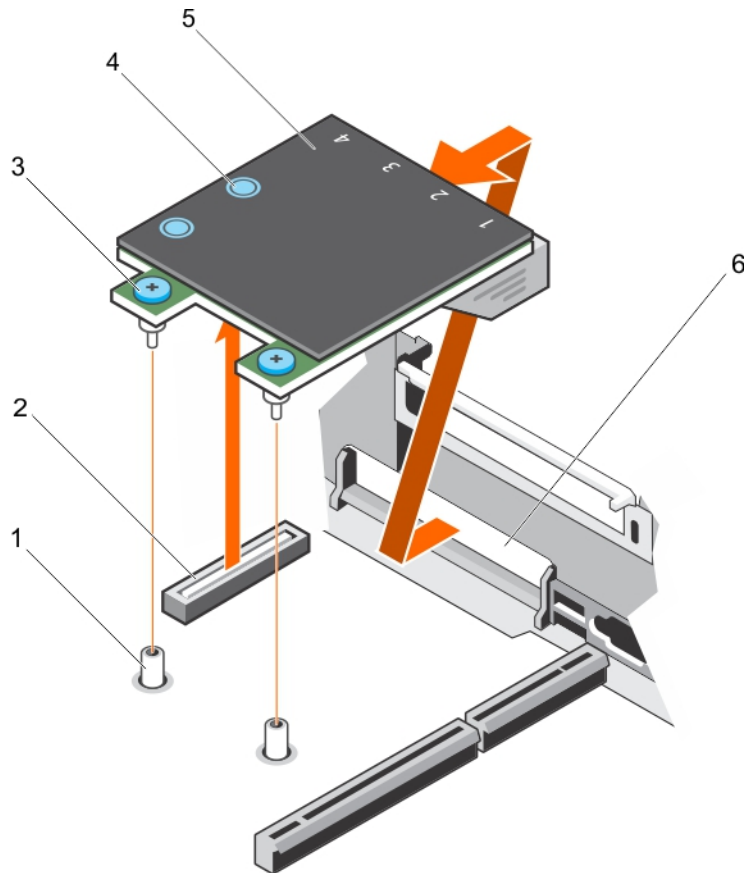

**Figure 38. Removing and installing the Network Daughter Card (NDC)**

- |                             |  |
|-----------------------------|--|
| 1. captive screw socket (2) | 2. connector on the system board           |
| 3. captive screw (2)        | 4. touch point (2)                         |
| 5. network daughter card    | 6. back panel slot for Ethernet connectors |

### Next steps

1. Replace the network daughter card. See [Installing the network daughter card](#).
2. Follow the procedure listed in [After working inside your system](#).

## Installing the network daughter card

### Prerequisites

1. Ensure that you read the [Safety instructions](#).
2. Follow the procedure listed in [Before working inside your system](#).
3. If applicable, remove the expansion card(s) in the expansion-card riser 2.
4. Keep the #1 Phillips screwdriver handy.

 **CAUTION:** Many repairs may only be done by a certified service technician. You should only perform troubleshooting and simple repairs as authorized in your product documentation, or as directed by the online or telephone service and support team. Damage due to servicing that is not authorized by Dell is not covered by your warranty. Read and follow the safety instructions that came with the product.

### Steps

1. Angle the card so that the Ethernet connectors fit through the slot in the back panel.
2. Align the captive screws on the card with the captive screw sockets on the system board.
3. Press the touch points on the card until the card connector is firmly seated on the system board connector.
4. Using a #1 Phillips screwdriver, tighten the captive screws to secure the network daughter card to the system board.

### Next steps

1. If applicable, install the expansion card(s) in the expansion-card riser 2.
2. Follow the procedure listed in [After working inside your system](#).

## System battery

### Replacing the system battery

#### Prerequisites

1. Ensure that you read the [Safety instructions](#).
2. Follow the procedure listed in [Before working inside your system](#).
3. Remove the cooling shroud.

 **WARNING:** There is a danger of a new battery exploding if it is incorrectly installed. Replace the battery only with the same or equivalent type recommended by the manufacturer. For more information, see the safety information that shipped with your system.

 **CAUTION:** Many repairs may only be done by a certified service technician. You should only perform troubleshooting and simple repairs as authorized in your product documentation, or as directed by the online or telephone service and support team. Damage due to servicing that is not authorized by Dell is not covered by your warranty. Read and follow the safety instructions that came with the product.

#### Steps

1. Locate the battery socket. For more information, see [System board connectors](#).

**⚠ CAUTION:** To avoid damage to the battery connector, you must firmly support the connector while installing or removing a battery.

2. Place your finger between the securing tabs at the negative side of the battery connector and lift the battery out of the socket.

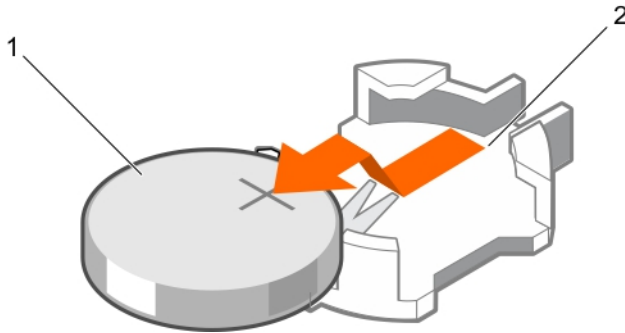

**Figure 39. Removing the system battery**

1. positive side of the battery connector
  2. system battery
  3. negative side of the battery connector
3. To install a new system battery, hold the battery with the "+" facing up and slide it under the securing tabs.
  4. Press the battery into the connector until it snaps into place.

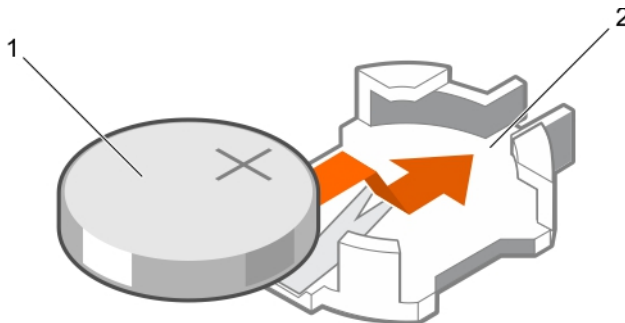

**Figure 40. Installing the system battery**

1. system battery
2. positive side of the battery

### Next steps

1. Install the cooling shroud.
2. Follow the procedure listed in [After working inside your system](#).
3. While booting, press F2 to enter System Setup and ensure the battery is operating properly.
4. Enter the correct time and date in System Setup **Time** and **Date** fields.
5. Exit System Setup.

## Power supply units

Your system supports one of the following:

- Two 495 W, 750 W, or 1100 W AC power supply modules or
- Two 1100 W DC power supply modules or
- Two 750 W mixed mode power supply modules

 **NOTE:** Titanium power supply unit is nominally rated for 200 VAC to 240 VAC input only.

 **NOTE:** When two identical PSUs are installed, power supply redundancy (1+1 – with redundancy or 2+0 – without redundancy) is configured in system BIOS. In redundant mode, power is supplied to the system equally from both PSUs when Hot Spare is disabled. When Hot Spare is enabled, one of the PSUs are put into standby when system usage is low to maximize efficiency.

 **NOTE:** If two power supply units are used, they must be of the same maximum output power.

 **NOTE:** For AC power supply units, use only power supply units with the Extended Power Performance (EPP) label on the back. Mixing power supply units from previous generations of servers can result in a power supply unit mismatch condition or failure to power on.

## Hot Spare feature

Your system supports the Hot Spare feature that significantly reduces the power overhead associated with PSU redundancy.

When the Hot Spare feature is enabled, one of the redundant power supplies is switched to a sleep state. The active PSU supports 100 percent of the load, thus operating at higher efficiency. The PSU in the sleep state monitors output voltage of the active PSU. If the output voltage of the active PSU drops, the PSU in the sleep state returns to an active output state.

If having both power supplies active is more efficient than having one PSU in a sleep state, the active PSU can also activate a sleeping PSU.

The default PSU settings are as follows:

- If the load on the active PSU is more than 50 percent, then the redundant PSU is switched to the active state.
- If the load on the active PSU is less than 20 percent, then the redundant PSU is switched to the sleep state

You can configure the Hot Spare feature by using the iDRAC settings. For more information about iDRAC settings, see the *Integrated Dell Remote Access Controller User's Guide* at [Dell.com/support/home](http://Dell.com/support/home).

## Removing the power supply unit blank

If you are installing a second power supply unit, remove the power supply unit blank in the bay by pulling the blank outward.

 **CAUTION:** To ensure proper system cooling, the power supply blank must be installed in the second power supply bay in a non-redundant configuration. Remove the power supply blank only if you are installing a second power supply.

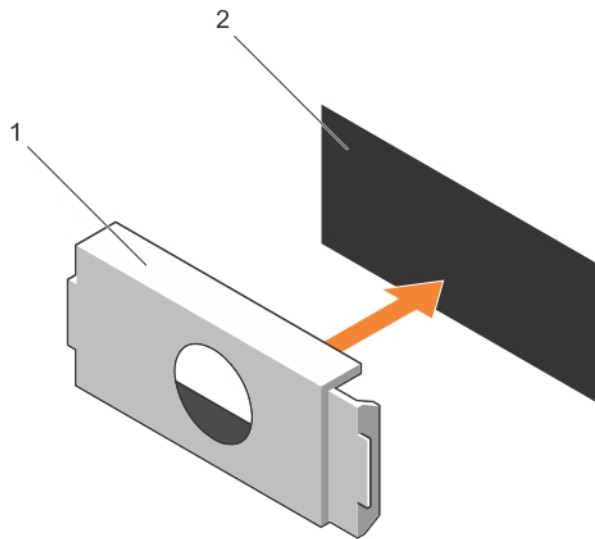

**Figure 41. Removing and installing the power supply blank**

1. power supply blank
2. power supply bay

## Installing the power supply unit blank

Install the power supply unit blank only in the second power supply unit bay.

To install the power supply unit blank, align the blank with the power supply unit bay and push it into the chassis until it clicks into place.

## Removing an AC power supply unit

### Prerequisites

**⚠ CAUTION:** Many repairs may only be done by a certified service technician. You should only perform troubleshooting and simple repairs as authorized in your product documentation, or as directed by the online or telephone service and support team. Damage due to servicing that is not authorized by Dell is not covered by your warranty. Read and follow the safety instructions that came with the product.

**⚠ CAUTION:** The system requires one power supply for normal operation. On power-redundant systems, remove and replace only one power supply at a time in a system that is powered on.

**🔧 NOTE:** You may have to unlatch and lift the optional cable management arm if it interferes with power supply removal. For information about the cable management arm, see the system's rack documentation.

### Steps

1. Disconnect the power cable from the power source and from the power supply unit you intend to remove and remove the cables from the strap.
2. Press the release latch and slide the power supply unit out of the chassis.

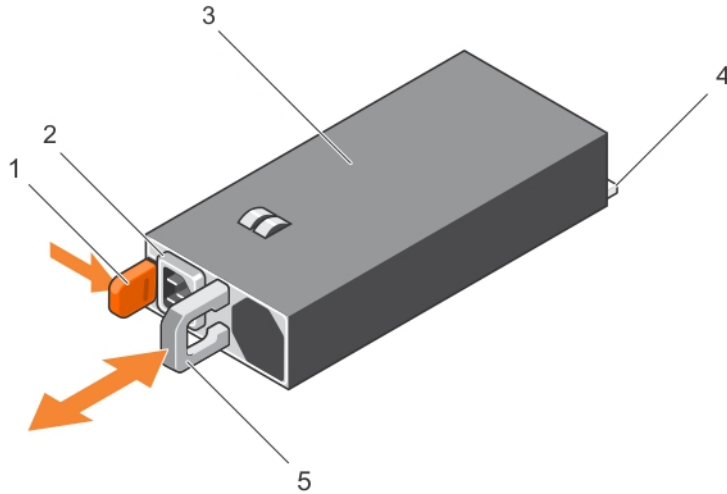

**Figure 42. Removing and installing an AC power supply unit**

- |                             |                                      |
|-----------------------------|--------------------------------------|
| 1. release latch            | 2. power supply unit cable connector |
| 3. power supply unit        | 4. connector                         |
| 5. power supply unit handle |                                      |

## Installing an AC power supply unit

### Prerequisites

**⚠ CAUTION:** Many repairs may only be done by a certified service technician. You should only perform troubleshooting and simple repairs as authorized in your product documentation, or as directed by the online or telephone service and support team. Damage due to servicing that is not authorized by Dell is not covered by your warranty. Read and follow the safety instructions that came with the product.

### Steps

1. Verify that both the power supply units are the same type and have the same maximum output power.

**📌 NOTE:** The maximum output power (shown in watts) is listed on the PSU label.

2. If applicable, remove the power supply unit blank.
3. Slide the new power supply unit into the chassis until the power supply unit is fully seated and the release latch snaps into place.

**📌 NOTE:** If you unlatched the cable management arm, re-latch it. For information about the cable management arm, see the system's rack documentation.





4. Connect the power cable to the power supply unit and plug the cable into a power outlet.

**⚠ CAUTION:** When connecting the power cable, secure the cable with the strap.

-  **NOTE:** When installing, hot-swapping, or hot-adding a new power supply unit, wait for 15 seconds for the system to recognize the power supply unit and determine its status. The power supply redundancy may not occur until discovery is complete. Wait until the new power supply unit is discovered and enabled before you remove the other power supply unit. The power-supply unit status indicator turns green to signify that the power supply unit is functioning properly.

## Wiring instructions for a DC power supply unit

Your system supports up to two –(48–60) V DC power supply units (PSUs).

-  **WARNING:** For equipment using –(48–60) V DC power supplies, a qualified electrician must perform all connections to DC power and to safety grounds. Do not attempt connecting to DC power or installing grounds yourself. All electrical wiring must comply with applicable local or national codes and practices. Damage due to servicing that is not authorized by Dell is not covered by your warranty. Read and follow all safety instructions that came with the product.
-  **CAUTION:** Wire the unit with copper only, unless otherwise specified, use only 10 American Wire Gauge (AWG) wire rated minimum 90 °C for source and return. Protect the –(48–60) V DC (1 wire) with a branch circuit over-current protection rated 50 A for DC with a high interrupt current rating.
-  **CAUTION:** Connect the equipment to a –(48–60) V DC supply source that is electrically isolated from the AC source (reliably grounded –(48–60) V DC SELV source). Ensure that the –(48–60) V DC source is efficiently secured to earth (ground).
-  **NOTE:** A readily accessible disconnect device that is suitably approved and rated shall be incorporated in the field wiring.

### Input requirements

- Supply voltage: –(48–60) V DC
- Current consumption: 32 A (maximum)

### Kit contents

- Dell part number 6RYJ9 terminal block or equivalent (1)
- #6-32 nut equipped with lock washer (1)

### Required tools

Wire-stripper pliers capable of removing insulation from size 10 AWG solid or stranded, insulated copper wire



-  **NOTE:** Use alpha wire part number 3080 or equivalent (65/30 stranding)

### Required wires

- One UL 10 AWG, 2 m maximum (stranded) black wire [–(48–60) V DC]
- One UL 10 AWG, 2 m maximum (stranded) red wire (V DC return)
- One UL 10 AWG, 2 m maximum green/yellow, green with a yellow stripe, stranded wire (safety ground)

## Removing a DC power supply unit

### Prerequisites

-  **WARNING:** For equipment using  $-48-60$  V DC power supplies, a qualified electrician must perform all connections to DC power and to safety grounds. Do not attempt connecting to DC power or installing grounds yourself. All electrical wiring must comply with applicable local or national codes and practices. Damage due to servicing that is not authorized by Dell is not covered by your warranty. Read and follow all safety instructions that came with the product.
-  **CAUTION:** The system requires one power supply for normal operation. On power-redundant systems, remove and replace only one power supply at a time in a system that is powered on.
-  **NOTE:** You may have to unlatch and lift the optional cable management arm if it interferes with power supply removal. For information about the cable management arm, see the system's rack documentation.

### Steps

1. Disconnect the power wires from the power source and the connector from the power supply you intend to remove.
2. Disconnect the safety ground wire.
3. Press the release latch and slide the power supply out of the chassis.

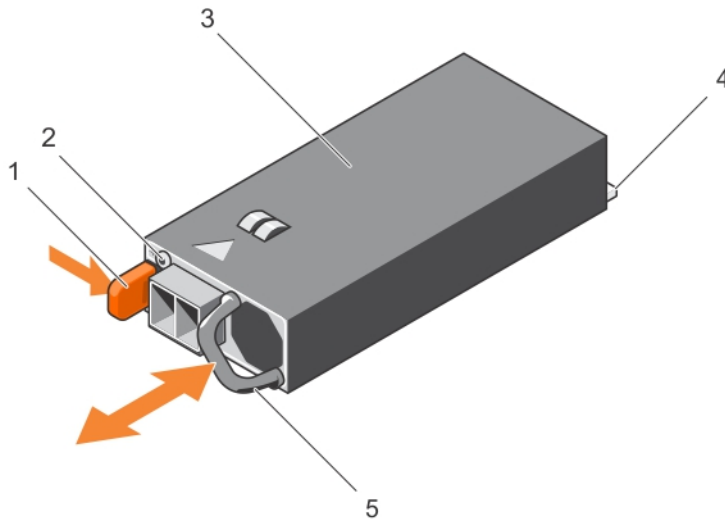

**Figure 43. Removing and installing a DC power supply**

- |                        |                                  |
|------------------------|----------------------------------|
| 1. release latch       | 2. power supply status indicator |
| 3. power supply        | 4. connector                     |
| 5. power supply handle |                                  |

## Installing a DC power supply unit

### Prerequisites

-  **WARNING:** For equipment using –(48–60) V DC power supplies, a qualified electrician must perform all connections to DC power and to safety grounds. Do not attempt connecting to DC power or installing grounds yourself. All electrical wiring must comply with applicable local or national codes and practices. Damage due to servicing that is not authorized by Dell is not covered by your warranty. Read and follow all safety instructions that came with the product.

### Steps

1. Verify that both the power supplies are of the same type and have the same maximum output power.

 **NOTE:** The maximum output power (shown in watts) is listed on the PSU label.

2. Slide the new power supply unit into the chassis until the power supply unit is fully seated and the release latch snaps into place.

 **NOTE:** If you unlatched the cable management arm, relatch it. For information about the cable management arm, see the systems rack documentation.

3. Connect the safety ground wire.
4. Install the DC power connector in the power supply unit.

 **CAUTION:** When connecting the power wires, secure the wires with the strap to the power supply handle.

5. Connect the wires to a DC power source.

 **NOTE:** When installing, hot-swapping, or hot-adding a new power supply, wait for 15 seconds for the system to recognize the power supply and determine its status. The power-supply status indicator turns green to signify that the power supply is functioning properly.

## System board

### Removing the system board

#### Prerequisites

 **CAUTION:** Many repairs may only be done by a certified service technician. You should only perform troubleshooting and simple repairs as authorized in your product documentation, or as directed by the online or telephone service and support team. Damage due to servicing that is not authorized by Dell is not covered by your warranty. Read and follow the safety instructions that came with the product.

 **CAUTION:** If you are using the Trusted Platform Module (TPM) with an encryption key, you may be prompted to create a recovery key during program or System Setup. Be sure to create and safely store this recovery key. If you replace this system board, you must supply the recovery key when you restart your system or program before you can access the encrypted data on your hard drives.

 **CAUTION:** Do not attempt to remove the TPM plug-in module from the motherboard. Once the TPM plug-in module is installed, it is cryptographically bound to that specific motherboard. Any attempt to remove an installed TPM plug-in module breaks the cryptographic binding, and it cannot be re-installed or installed on another motherboard.

1. Ensure that you read the [Safety instructions](#).
2. Follow the procedure listed in [Before working inside your system](#).

3. Remove the following:
  - a. cooling shroud
  - b. cooling-fan assembly
  - c. hard-drive tray (if installed)
  - d. power supply unit(s)
  - e. all expansion-card risers
  - f. integrated storage controller card
  - g. internal dual SD module
  - h. internal USB key (if installed)
  - i. PCIe card holder
  - j. cable retention bracket
  - k. heat sink(s)/heat-sink blank(s)
  - l. processors(s)/processor blank(s)

 **CAUTION: To prevent damage to the processor pins when replacing a faulty system board, ensure that you cover the processor socket with the processor protective cap.**

- m. memory modules and memory module blanks
- n. network daughter card

### Steps

1. Disconnect the mini SAS cable from the system board.
2. Disconnect all cables from the system board.

 **CAUTION: Take care not to damage the system identification button while removing the system board from the chassis.**

 **CAUTION: Do not lift the system board by holding a memory module, processor, or other components.**

3. Hold the system-board holder, lift the blue release pin, lift the system board and slide it toward the front of the chassis.  
Sliding the system board toward the front of the chassis disengages the connectors from the back of the chassis slots.
4. Lift the system board out of the chassis.

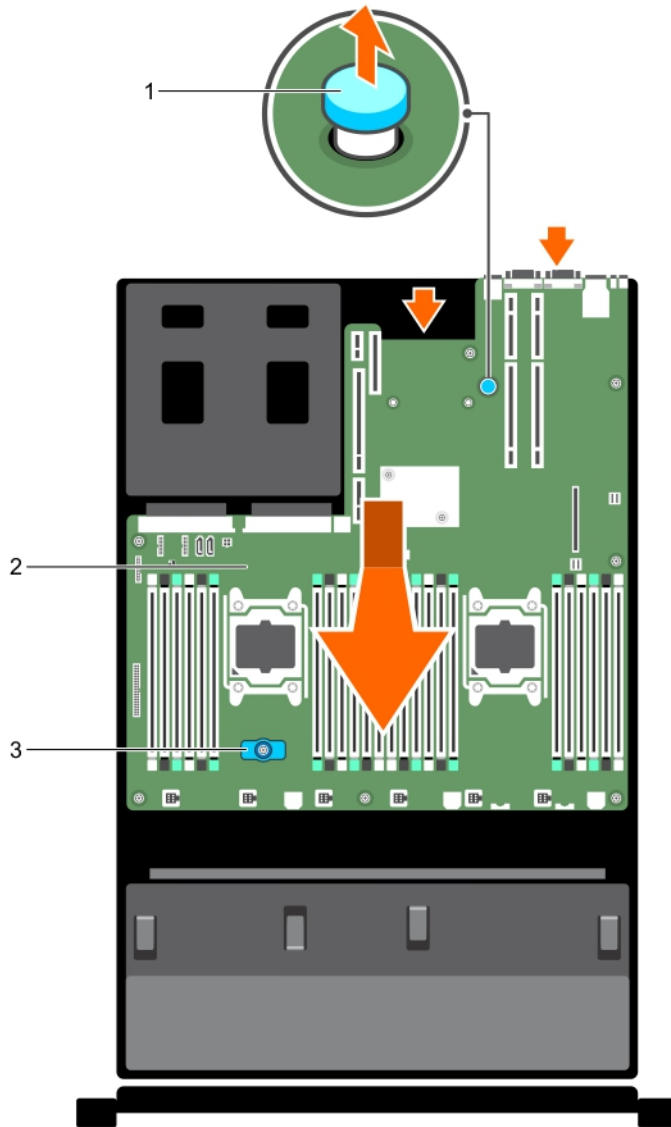

Figure 44. Removing and installing the system board

1. release pin
2. system board
3. system-board holder

#### Next steps

1. Replace the system board. See [Installing the system board](#).
2. Follow the procedure listed in [After working inside your system](#).

## Installing the system board

#### Prerequisites

1. Ensure that you read the [Safety instructions](#).

2. Follow the procedure listed in [Before working inside your system](#).

 **CAUTION:** Many repairs may only be done by a certified service technician. You should only perform troubleshooting and simple repairs as authorized in your product documentation, or as directed by the online or telephone service and support team. Damage due to servicing that is not authorized by Dell is not covered by your warranty. Read and follow the safety instructions that came with the product.

 **CAUTION:** This repair may only be done by a certified service technician. You should only perform troubleshooting and simple repairs as authorized in your product documentation, or as directed by the online or telephone service and support team. Damage due to servicing that is not authorized by Dell is not covered by your warranty. Read and follow the safety instructions that came with the product.

### Steps

1. Unpack the new system board assembly.

 **CAUTION:** Do not lift the system board by holding a memory module, processor, or other components.

 **CAUTION:** Take care not to damage the system identification button while placing the system board into the chassis.

2. Hold the touch points and lower the system board into the chassis.
3. Push the system board toward the back of the chassis until the board clicks into place.

### Next steps

1. Install the Trusted Platform Module (TPM). For information about how to install TPM, see [Installing the Trusted Platform Module](#). For more information about TPM, see [Trusted Platform Module](#).

 **NOTE:** The TPM plug-in module is attached to the motherboard and cannot be removed. A replacement TPM plug-in module is provided for all motherboard replacements where a TPM plug-in module was installed.

2. Replace the following:
  - a. Cable retention bracket
  - b. PCIe card holder
  - c. Hard-drive tray (if applicable)
  - d. Integrated storage controller card
  - e. Internal USB key (if applicable)
  - f. Internal dual SD module
  - g. All expansion-card risers
  - h. Heat sink(s)/heat-sink blank(s) and processors(s)/processor blank(s)
  - i. Memory modules and memory module blanks
  - j. Network daughter card
  - k. Cooling-fan assembly
  - l. Cooling shroud
  - m. Power supply unit(s)
3. Reconnect all cables to the system board.

 **NOTE:** Ensure that the cables inside the system are routed along the chassis wall and secured using the cable securing bracket.

4. Follow the procedure listed in [After working inside your system](#).
5. Import your new or existing iDRAC Enterprise license. For more information, see *Integrated Dell Remote Access Controller User's Guide*, at [Dell.com/esmmanuals](http://Dell.com/esmmanuals).

6. Ensure that you:
  - a. Use the **Easy Restore** feature to restore the Service Tag. For more information, see [Restoring the Service Tag using Easy Restore](#).
  - b. If the Service Tag is not backed up in the backup flash device, enter the system Service Tag manually. For more information, see [Entering the system Service Tag using System Setup](#).
  - c. Update the BIOS and iDRAC versions.
  - d. Re-enable the Trusted Platform Module (TPM). For more information, see [Re-enabling the TPM for TXT users](#).

### Entering the system Service Tag using System Setup

If you know the system Service Tag, use the System Setup menu to enter the Service Tag.

1. Turn on the system.
2. Press F2 to go to the System Setup.
3. Click **Service Tag Settings**.
4. Type the Service Tag.



**NOTE:** You can type the only when the **Service Tag** field is empty. Ensure that you enter the correct Service Tag. Once the Service Tag is entered, it cannot be updated or changed.

5. Click **Ok**.
6. Import your new or existing iDRAC Enterprise license.

For more information, see *Integrated Dell Remote Access Controller User's Guide*, at [Dell.com/idracmanuals](http://Dell.com/idracmanuals).

### Restoring the Service Tag using Easy Restore

Use the Easy Restore feature if you do not know the Service Tag of your system. The Easy Restore feature allows you to restore your system's Service Tag, license, UEFI configuration, and the system configuration data after replacing the system board. All data is backed up in a backup flash device automatically. If BIOS detects a new system board and the Service Tag in the backup flash device, BIOS prompts the user to restore the backup information.

1. Turn on the system.

If BIOS detects a new system board, and if the Service Tag is present in the backup flash device, BIOS displays the Service Tag, the status of the license, and the **UEFI Diagnostics** version.
2. Do one of the following:
  - To restore the Service Tag, license, and diagnostics information, press Y.
  - To navigate to the Lifecycle Controller based restore options, press N.
  - To restore data from a previously created **Hardware Server Profile**, press F10.

After the restore process is complete, BIOS prompts to restore the system configuration data.

3. Do one of the following:
  - Press Y to restore the system configuration data.
  - Press N to use the default configuration settings.

After the restore process is complete, the system restarts.

# Trusted Platform Module

The Trusted Platform Module (TPM) is used to generate/store keys, protect/authenticate passwords, and create/store digital certificates. TPM can also be used to enable the BitLocker hard drive encryption feature in Windows Server.

 **CAUTION: Do not attempt to remove the Trusted Platform Module (TPM) from the system board. Once the TPM is installed, it is cryptographically bound to that specific system board. Any attempt to remove an installed TPM breaks the cryptographic binding, and it cannot be re-installed or installed on another system board.**

## Installing the Trusted Platform Module

### Prerequisites

 **CAUTION: Many repairs may only be done by a certified service technician. You should only perform troubleshooting and simple repairs as authorized in your product documentation, or as directed by the online or telephone service and support team. Damage due to servicing that is not authorized by Dell is not covered by your warranty. Read and follow the safety instructions that came with the product.**

Ensure that you read the [.Safety instructions](#)

### Steps

1. Locate the TPM connector on the system board.
2. Align the edge connectors on the TPM with the slot on the TPM connector.
3. Insert the TPM into the TPM connector such that the plastic bolt aligns with the slot on the system board.
4. Press the plastic bolt until the bolt snaps into place.

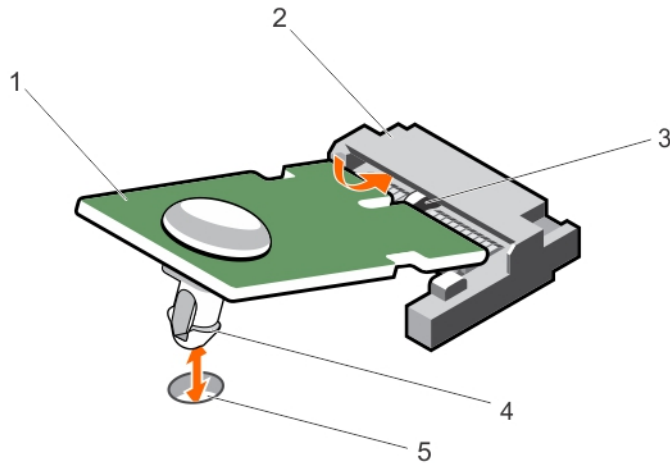

**Figure 45. Installing the TPM**

1. TPM
2. TPM connector
3. slot on the TPM connector
4. plastic bolt
5. slot on the system board

## Re-enabling the TPM for BitLocker users

Initialize the TPM.

For more information on initializing the TPM, go to <http://technet.microsoft.com/en-us/library/cc753140.aspx>.

The **TPM Status** changes to **Enabled, Activated**.

## Re-enabling the TPM for TXT users

1. While booting your system, press F2 to go to **System Setup**.
2. On the **System Setup Main Menu** screen, click **System BIOS** → **System Security**.
3. From the **TPM Security** option, select **On with Pre-boot Measurements**.
4. From the **TPM Command** option, select **Activate**.
5. Save the settings.
6. Restart your system.
7. Go to **System Setup**.
8. On the **System Setup Main Menu** screen, click **System BIOS** → **System Security**.
9. From the **Intel TXT** option, select **On**.

# Hard drives

Your system supports Enterprise-class hard drives, which are designed for 24x7 operating environment. Selecting the correct drive class optimizes quality, functionality, performance, and reliability of the hard drives.

The Nutanix Web GUI provides a feature to help locate a specific HDD. When the front LEDs are turned on using the Nutanix Web GUI, the HDD or SSD you are trying to locate continues to blink as long as there is I/O activity. The other HDDs or SSDs blink twice every second (in addition to blinking because of I/O activity). The HDD or SSD you are trying to locate does not blink twice every second.

Due to industry advances, in some cases, the larger capacity drives have been changed to a larger sector size. The larger sector size can have impacts on operating systems and applications. For more information about these hard drives, see the *512e and 4Kn Disk Formats* whitepaper and *4K Sector HDD FAQ* document at [Dell.com/xcseriesmanuals](http://Dell.com/xcseriesmanuals)

All hard drives are connected to the system board through the hard-drive backplane. Hard drives are supplied in hot-swappable hard-drive carriers that fit in the hard-drive slots.

 **NOTE:** After the Nutanix Web GUI has prepared the disk for removal, you can remove it.

 **CAUTION:** Before attempting to remove or install a hard drive while the system is running, see the documentation for the storage controller card to ensure that the host adapter is configured correctly to support hot-swap hard drive removal and insertion.

 **CAUTION:** Do not turn off or reboot your system while the hard drive is being formatted. Doing so can cause a hard drive failure.

Use only hard drives that have been tested and approved for use with the hard-drive backplane.

When you format a hard drive, allow enough time for the formatting to be completed. Be aware that high-capacity hard drives can take a number of hours to format.

## Removing a 3.5-inch hard-drive blank

### Prerequisites

 **CAUTION:** Many repairs may only be done by a certified service technician. You should only perform troubleshooting and simple repairs as authorized in your product documentation, or as directed by the online or telephone service and support team. Damage due to servicing that is not authorized by Dell is not covered by your warranty. Read and follow the safety instructions that came with the product.

 **CAUTION:** To maintain proper system cooling, all empty hard-drive slots must have drive blanks installed.

1. Ensure that you read the [Safety instructions](#).
2. If installed, remove the front bezel.

### Steps

Press the release button and slide the blank out of the hard-drive slot.

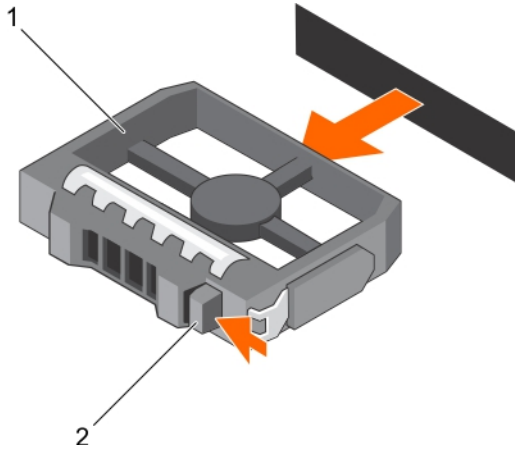

**Figure 46. Removing and installing a 3.5-inch hard-drive blank**

1. hard-drive blank

2. release button

#### Next steps

If applicable, install the front bezel.

## Installing a 3.5-inch hard-drive blank

#### Prerequisites

1. Ensure that you read the [Safety instructions](#).
2. If installed, remove the front bezel.

#### Steps

Insert the hard-drive blank into the hard-drive slot until the release button clicks into place.

#### Next steps

If applicable, install the front bezel.

## Removing a hot-swap hard drive

The Nutanix Web GUI provides a feature to help locate a specific HDD. When the front LEDs are turned on using the Nutanix Web GUI, the HDD or SSD you are trying to locate continues to blink as long as there is I/O activity. The other HDDs or SSDs blink twice every second (in addition to blinking because of I/O activity). The HDD or SSD you are trying to locate does not blink twice every second.

#### Prerequisites

**⚠ CAUTION:** Many repairs may only be done by a certified service technician. You should only perform troubleshooting and simple repairs as authorized in your product documentation, or as directed by the online or telephone service and support team. Damage due to servicing that is not authorized by Dell is not covered by your warranty. Read and follow the safety instructions that came with the product.

**✍ NOTE:** After the Nutanix Web GUI has prepared the disk for removal, you can remove it.

1. Ensure that you read the [Safety instructions](#).
2. If applicable, remove the bezel.
3. If applicable, remove the system cover to remove hot-swap drives inside your system. Follow the procedure listed in [Before working inside your system](#).

- Using the management software, prepare the hard drive for removal. Wait until the indicators on the hard-drive carrier signal that the hard drive can be removed safely. For more information, see the documentation for the storage controller.  
If the hard drive is online, the green activity/fault indicator flashes as the drive is turned off. When the hard-drive indicators are off, the hard drive is ready for removal.

**CAUTION:** To prevent data loss, ensure that your operating system supports hot-swap drive installation. See the documentation supplied with your operating system.

#### Steps

- Press the release button to open the hard-drive carrier release handle.
- Slide the hard-drive carrier out of the hard-drive slot.

**CAUTION:** To maintain proper system cooling, all empty hard-drive slots must have hard-drive blanks installed.

- If you are not replacing the hard drive immediately, insert a hard-drive blank in the empty hard-drive slot.

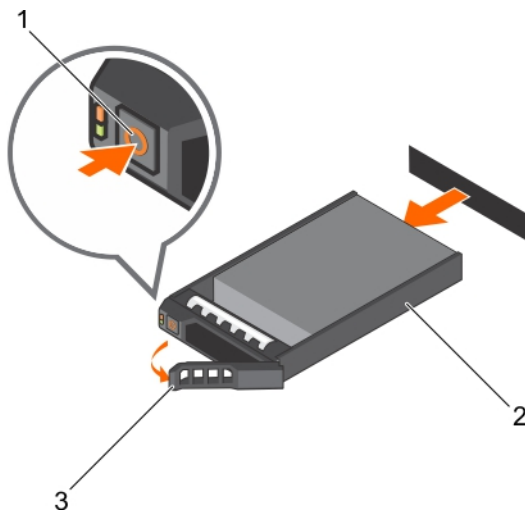

Figure 47. Removing and installing a hot-swap hard drive

- release button
- hard-drive carrier
- hard-drive carrier handle

## Installing a hot-swap hard drive

#### Prerequisites

**CAUTION:** Many repairs may only be done by a certified service technician. You should only perform troubleshooting and simple repairs as authorized in your product documentation, or as directed by the online or telephone service and support team. Damage due to servicing that is not authorized by Dell is not covered by your warranty. Read and follow the safety instructions that came with the product.

**CAUTION:** Use only hard drives that have been tested and approved for use with the hard-drive backplane.

**CAUTION:** When installing a hard drive, ensure that the adjacent drives are fully installed. Inserting a hard-drive carrier and attempting to lock its handle next to a partially installed carrier can damage the partially installed carrier's shield spring and make it unusable.

- △ **CAUTION:** To prevent data loss, ensure that your operating system supports hot-swap drive installation. See the documentation supplied with your operating system.
- △ **CAUTION:** When a replacement hot-swappable hard drive is installed and the system is powered on, the hard drive automatically begins to rebuild. Make absolutely sure that the replacement hard drive is blank or contains data that you wish to have over-written. Any data on the replacement hard drive is immediately lost after the hard drive is installed.

#### Steps

1. If a HDD blank is installed in the HDD slot, remove it.
2. Install a HDD in the HDD carrier.
3. Press the release button on the front of the HDD carrier and open the HDD carrier handle.
4. Insert the HDD carrier into the HDD slot until the carrier connects with the backplane.
5. Close the HDD carrier handle to lock the HDD in place.

## Removing a hard drive from a hard-drive carrier

#### Prerequisites

1. Keep the #1 Phillips screwdriver handy.
2. Remove the hard-drive carrier from the system.

#### Steps

1. Remove the screws from the slide rails on the hard-drive carrier.
2. Lift the hard drive out of the hard-drive carrier.

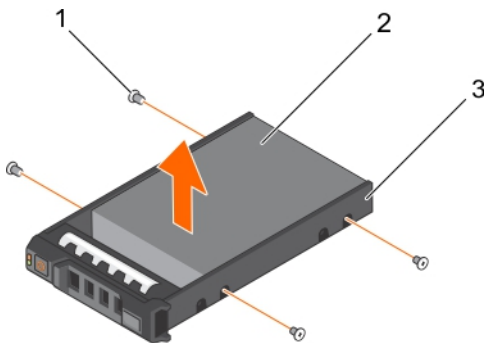

Figure 48. Removing and installing a hard drive into a hard-drive carrier

1. screw (4)
2. hard drive
3. hard-drive carrier

## Installing a hard drive into a hard-drive carrier

#### Prerequisites

- △ **CAUTION:** Many repairs may only be done by a certified service technician. You should only perform troubleshooting and simple repairs as authorized in your product documentation, or as directed by the online or telephone service and support team. Damage due to servicing that is not authorized by Dell is not covered by your warranty. Read and follow the safety instructions that came with the product.

### Steps

1. Insert the hard drive into the hard-drive carrier with the connector end of the hard drive toward the back.
2. Align the screw holes on the hard drive with the set of screw holes on the hard-drive carrier.  
When aligned correctly, the back of the hard drive is flush with the back of the hard-drive carrier.
3. Attach the screws to secure the hard drive to the hard-drive carrier.

## Hard-drive backplane

3.5-inch (x12) SAS/SATA backplane.

### Removing the hard-drive backplane

#### Prerequisites

1. Ensure that you read the [Safety instructions](#).
2. Follow the procedure listed in [Before working inside your system](#).
3. Remove the cooling shroud.
4. Remove the cooling-fan assembly.
5. Remove all hard drives.

 **CAUTION:** Many repairs may only be done by a certified service technician. You should only perform troubleshooting and simple repairs as authorized in your product documentation, or as directed by the online or telephone service and support team. Damage due to servicing that is not authorized by Dell is not covered by your warranty. Read and follow the safety instructions that came with the product.

 **CAUTION:** To prevent damage to the drives and backplane, you must remove the hard drives from the system before removing the backplane.

 **CAUTION:** You must note the number of each hard drive and temporarily label them before removal so that you can replace them in the same locations.

#### Steps

1. Disconnect the SAS/SATA data, signal, and power cable(s) from the backplane.
2. Press the release tabs and lift the backplane upward and slide it toward the back of the chassis.

 **NOTE:** To prevent damage to the control panel flex cable, unlatch the blocking tab on the connector before removing the flex cable. Do not bend the flex cable at the connector. To unlatch the blocking tab for the x12 backplane, pull the locking tab up. For the x18 and x2 backplanes, rotate the locking tab 90 degrees clockwise.

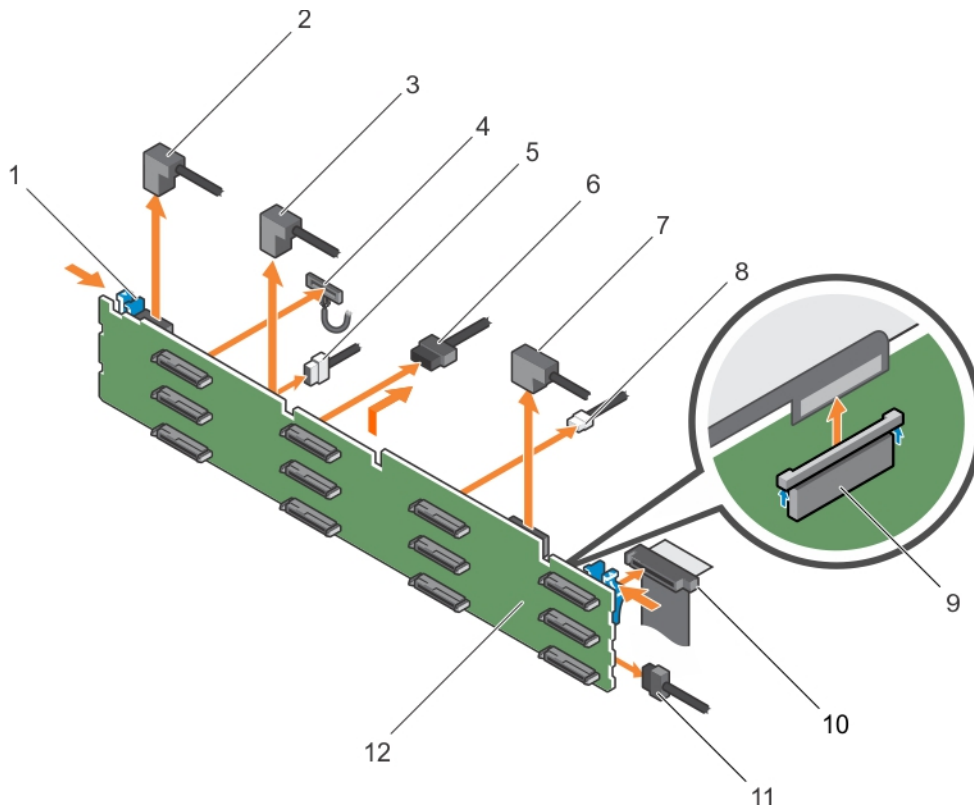

**Figure 49. Removing and installing the 3.5-inch (x12) SAS/SATA backplane**

- |                           |   |
|---------------------------|---|
| 1. release tab (2)        | 2. SAS cable A2                         |
| 3. SAS cable A1           | 4. left ear control panel cable         |
| 5. backplane signal cable | 6. backplane power cable (2)            |
| 7. SAS cable A0/B0        | 8. USB cable                            |
| 9. control panel cable    | 10. right ear control panel flex cable  |
| 11. hard-drive backplane  | 12. hard-drive backplane connector (12) |

#### Next steps

1. Replace the hard-drive backplane. See [Installing the hard-drive backplane](#).
2. Follow the procedure listed in [After working inside your system](#).

## Installing the hard-drive backplane

#### Prerequisites

1. Ensure that you read the [Safety instructions](#).
2. Follow the procedure listed in [Before working inside your system](#).

**⚠ CAUTION:** Many repairs may only be done by a certified service technician. You should only perform troubleshooting and simple repairs as authorized in your product documentation, or as directed by the online or telephone service and support team. Damage due to servicing that is not authorized by Dell is not covered by your warranty. Read and follow the safety instructions that came with the product.

 **CAUTION:** To prevent damage to the control panel flex cable, do not bend the control panel flex cable after it is inserted into the connector.

#### Steps

1. Use the hooks on the chassis as guides to align the hard-drive backplane.
2. Lower the hard-drive backplane until the release tabs snap into place.
3. Connect the SAS/SATA/SSD data, signal, and power cable(s) to the backplane.

#### Next steps

1. Replace the cooling-fan assembly.
2. Replace the cooling shroud.
3. Install the hard drives in their original locations.
4. Follow the procedure listed in [After working inside your system](#).

## Removing the optional hard-drive backplane (back)

#### Prerequisites

1. Ensure that you read the [Safety instructions](#).
2. Follow the procedure listed in [Before working inside your system](#).
3. Remove both hard drives.

 **CAUTION:** Many repairs may only be done by a certified service technician. You should only perform troubleshooting and simple repairs as authorized in your product documentation, or as directed by the online or telephone service and support team. Damage due to servicing that is not authorized by Dell is not covered by your warranty. Read and follow the safety instructions that came with the product.

 **CAUTION:** To prevent damage to the drives and backplane, you must remove the hard drives from the system before removing the backplane.

 **CAUTION:** You must note the number of each hard drive and temporarily label them before removal so that you can replace them in the same locations.

#### Steps

1. Disconnect all the cables from the backplane.
2. Lift the release pin and slide the backplane toward the front of the chassis.
3. Lift the backplane to remove it from the chassis.

## Removing the control panel

#### Prerequisites

1. Ensure that you read the [Safety instructions](#).
2. Follow the procedure listed in [Before working inside your system](#).
3. Keep the T15 Torx screwdriver handy.

 **CAUTION:** Many repairs may only be done by a certified service technician. You should only perform troubleshooting and simple repairs as authorized in your product documentation, or as directed by the online or telephone service and support team. Damage due to servicing that is not authorized by Dell is not covered by your warranty. Read and follow the safety instructions that came with the product.

**⚠ CAUTION: Do not use excessive force when removing the control panel cable as it can damage the connectors.**

#### Steps

1. Disconnect the control panel cable from the hard-drive backplane by pulling on the plastic pull tab.
2. Remove the screws that secure the control panel to the chassis.
3. Fold the plastic pull tab close to the connector.
4. Pull out the control panel cable as you guide the connector and the plastic pull tab through the channel on the chassis.

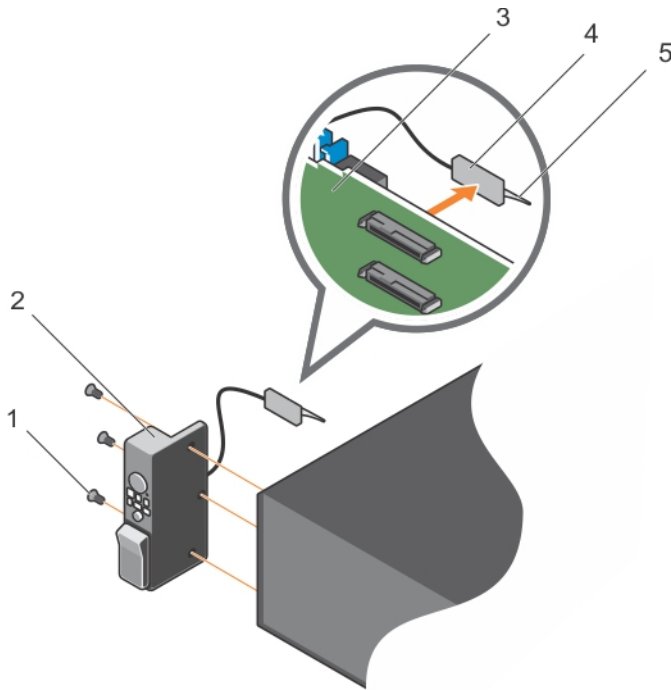

**Figure 50. Removing and installing the control panel**

- |                         |                  |
|-------------------------|------------------|
| 1. screw (3)            | 2. control panel |
| 3. hard-drive backplane | 4. connector     |
| 5. plastic pull tab     |                  |

#### Next steps

1. Replace the control panel. See [Installing the control panel](#).
2. Follow the procedure listed in [After working inside your system](#).

## Installing the control panel

#### Prerequisites

1. Ensure that you read the [Safety instructions](#).
2. Keep the #2 Phillips screwdriver handy.

 **CAUTION:** Many repairs may only be done by a certified service technician. You should only perform troubleshooting and simple repairs as authorized in your product documentation, or as directed by the online or telephone service and support team. Damage due to servicing that is not authorized by Dell is not covered by your warranty. Read and follow the safety instructions that came with the product.

#### Steps

1. Replace the blank information tag in the new control panel with the information tag retained from the old control panel.



**NOTE:** Information tag lists system information such as Service Tag, NIC, MAC address, and so on.

2. To install the information tag, push the information tag into the control-panel slot.
3. Connect all the applicable cables to the control panel.
4. Slide the control panel into the slot in the chassis and secure the module with the screw.

#### Next steps

Follow the procedure listed in [After working inside your system](#).

## Removing the I/O panel

#### Prerequisites

1. Ensure that you read the [Safety instructions](#).
2. Follow the procedure listed in [Before working inside your system](#).
3. Keep the T15 Torx screwdriver handy.

 **CAUTION:** Many repairs may only be done by a certified service technician. You should only perform troubleshooting and simple repairs as authorized in your product documentation, or as directed by the online or telephone service and support team. Damage due to servicing that is not authorized by Dell is not covered by your warranty. Read and follow the safety instructions that came with the product.

 **CAUTION:** To prevent damage to the I/O cable, you must release the locking tab before removing or installing the I/O cable from the connector on the hard-drive backplane.

#### Steps

1. Rotate the locking tab on the I/O cable connector clockwise 90 degrees to release the lock.  
For more information on the locking tab, see [Removing the hard-drive backplane](#).
2. Disconnect the I/O cable from the backplane.
3. Remove the screws securing the I/O panel to the chassis.
4. Pull out the I/O panel cable through the channel on the chassis.

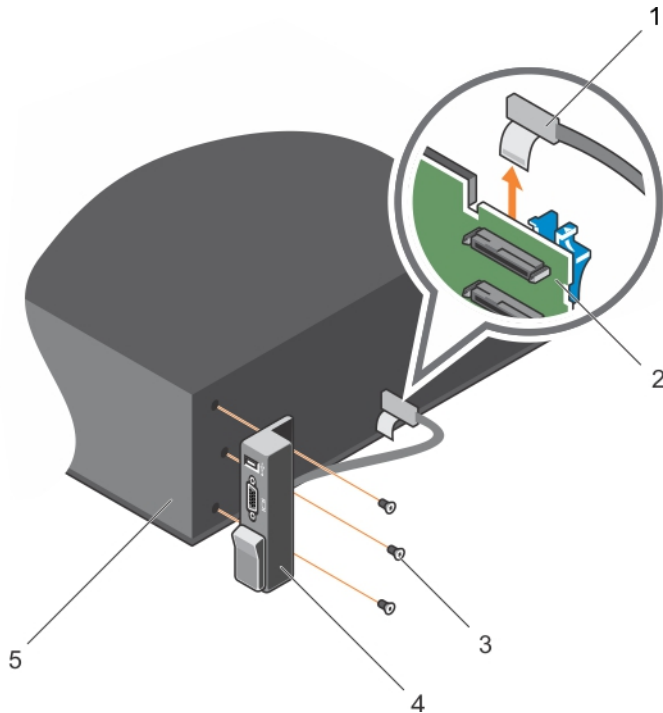

**Figure 51. Removing and installing the I/O panel**

- |                    |                         |
|--------------------|-------------------------|
| 1. I/O panel cable | 2. hard-drive backplane |
| 3. screw (3)       | 4. I/O panel            |
| 5. chassis         |                         |

#### Next steps

1. Replace the I/O panel. See [Installing the I/O panel](#).
2. Follow the procedure listed in [After working inside your system](#).

## Installing the I/O panel

#### Prerequisites

1. Ensure that you read the [Safety instructions](#).
2. Follow the procedure listed in [Before working inside your system](#).
3. Keep the T15 Torx screwdriver handy.

**⚠ CAUTION:** Many repairs may only be done by a certified service technician. You should only perform troubleshooting and simple repairs as authorized in your product documentation, or as directed by the online or telephone service and support team. Damage due to servicing that is not authorized by Dell is not covered by your warranty. Read and follow the safety instructions that came with the product.

#### Steps

1. Fold the PPID label around the cable.
2. Push the cable until the cable passes completely through the channel.

 **CAUTION:** To prevent damage to the I/O cable, you must release the locking tab before removing or installing the I/O cable from the connector on the hard-drive backplane.

3. If locked, rotate the locking tab on the I/O cable connector clockwise 90 degrees to release the lock.
4. Connect the I/O panel cable to the connector on the hard-drive backplane.
5. Rotate the locking tab on the I/O cable connector counter clockwise 90 degrees to secure the lock.
6. Tighten the screws to secure the control panel to the chassis.

 **NOTE:** You must route the cable properly to prevent it from being pinched or crimped.

#### Next steps

Follow the procedure listed in [After working inside your system](#).

## Removing the hard-drive backplane from the hard-drive tray

#### Prerequisites

 **CAUTION:** Many repairs may only be done by a certified service technician. You should only perform troubleshooting and simple repairs as authorized in your product documentation, or as directed by the online or telephone service and support team. Damage due to servicing that is not authorized by Dell is not covered by your warranty. Read and follow the safety instructions that came with the product.

1. Ensure that you read the [Safety instructions](#).
2. Follow the procedure listed in [Before working inside your system](#).
3. Disconnect all the cables from the backplane.
4. Remove the hard-drive carriers.
5. Remove the hard-drive tray from the system.

 **CAUTION:** To prevent damage to the drives and backplane, you must remove the hard drives from the system before removing the backplane.

 **CAUTION:** You must note the number of each hard drive and temporarily label them before removal so that you can replace them in the same locations.

#### Steps

Press the release tabs and lift the backplane out of the hard-drive tray.

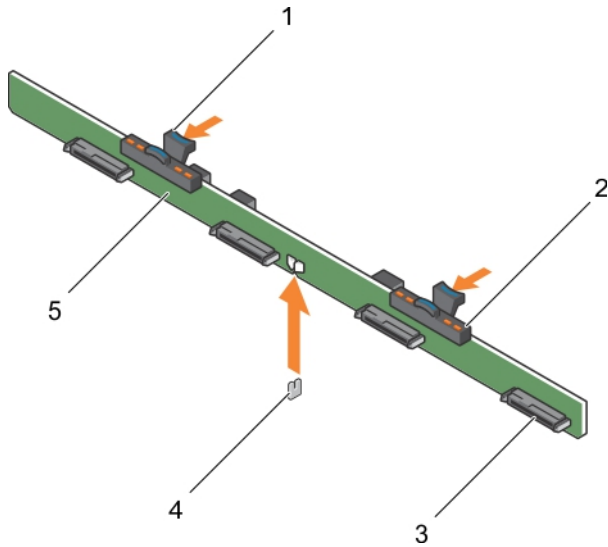

Figure 52. Removing and installing the 3.5 inch (x4) hard-drive backplane

- |                             |                          |
|-----------------------------|--------------------------|
| 1. release tab (2)          | 2. hard-drive indicators |
| 3. hard-drive connector (4) | 4. guide pin             |
| 5. hard-drive backplane     |                          |

## Installing the hard-drive backplane in the hard-drive tray

### Prerequisites

1. Ensure that you read the [Safety instructions](#).
2. Follow the procedure listed in [Before working inside your system](#).

**⚠ CAUTION:** Many repairs may only be done by a certified service technician. You should only perform troubleshooting and simple repairs as authorized in your product documentation, or as directed by the online or telephone service and support team. Damage due to servicing that is not authorized by Dell is not covered by your warranty. Read and follow the safety instructions that came with the product.

### Steps

1. Align the hard-drive backplane with the guide pin on the chassis and lower the hard-drive backplane on the chassis until it is firmly seated.
2. Install the hard-drives carriers in to the hard-drive tray.
3. Install the hard-drive tray in to the chassis.
4. Follow the procedure listed in [After working inside your system](#).

# Troubleshooting your system

## Safety first—for you and your system

 **CAUTION:** Many repairs may only be done by a certified service technician. You should only perform troubleshooting and simple repairs as authorized in your product documentation, or as directed by the online or telephone service and support team. Damage due to servicing that is not authorized by Dell is not covered by your warranty. Read and follow the safety instructions that came with the product.

## Troubleshooting system startup failure

You must boot to the same boot mode in which you installed the operating system.

For all other startup issues, note the system messages that appear on the screen.

## Troubleshooting external connections

Ensure that all external cables are securely attached to the external connectors on your system before troubleshooting any external devices.

## Troubleshooting the video subsystem

1. Check the system and power connections to the monitor.
2. Check the video interface cabling from the system to the monitor.
3. Run the appropriate diagnostic test.

If the tests run successfully, the problem is not related to video hardware.

If the tests fail, see [Getting Help](#).

## Troubleshooting a USB device

### About this task

Use the following steps to troubleshoot a USB keyboard/mouse. For other USB devices, go to step 7.

### Steps

1. Disconnect the keyboard and mouse cables from the system and reconnect them.
2. If the problem persists, connect the keyboard/mouse to the USB ports on the opposite side of the system.
3. If the problem is resolved, restart the system, enter the System Setup, and check if the non-functioning USB ports are enabled.

Check if USB 3.0 is enabled in System Setup. If enabled, disable it and see if the issue is resolved (older operating systems may not support USB 3.0).

4. On the **IDRAC Settings Utility** screen, ensure that the **USB Management Port Mode** is configured as **Automatic** or **Standard OS Use**.
5. Replace the keyboard/mouse with a working keyboard/mouse.  
If the problem is not resolved, proceed to the next step to begin troubleshooting other USB devices attached to the system.
6. Power down all attached USB devices and disconnect them from the system.
7. Restart the system and if your keyboard is functioning, go to the System Setup.
8. Verify that all USB ports are enabled on the **Integrated Devices** screen, in the System Setup options.
9. Check if USB 3.0 is enabled in System Setup. If it is enabled, disable it and restart your system.  
If your keyboard is not functioning, you can also use remote access.
10. If the system is not accessible, reset the NVRAM\_CLR jumper inside your system and restore the BIOS to the default settings.
11. On the **IDRAC Settings Utility** screen, ensure that the **USB Management Port Mode** is configured as **Automatic** or **Standard OS Use**.
12. Reconnect and power on each USB device one at a time.
13. If a USB device causes the same problem, power down the device, replace the USB cable with a known good cable, and power up the device.

#### Next steps

If all troubleshooting fails, see [Getting Help](#).

## Troubleshooting iDRAC Direct (USB XML configuration)

For information on USB storage device and server configuration, see the Integrated Dell Remote Access Controller User's Guide at [Dell.com/esmanuals](http://Dell.com/esmanuals).

#### Steps

1. Ensure your USB storage device is connect to the front USB Management Port, identified by  icon.
2. Ensure your USB storage device is configured with an NTFS or a FAT32 file system with only one partition.
3. Verify that the USB storage device is configured correctly. For more information on configuring the USB storage device, see the Integrated Dell Remote Access Controller User's Guide at [Dell.com/esmanuals](http://Dell.com/esmanuals).
4. On the **IDRAC Settings Utility** screen, ensure that the **USB Management Port Mode** is configured as **Automatic** or **iDRAC Direct Only**.
5. Ensure the **iDRAC Managed: USB XML Configuration** option is either **Enabled** or **Enabled only when the server has default credential settings**.
6. Remove and reinsert the USB storage device.
7. If import operation does not work, try with a different USB storage device.

#### Next steps

If all troubleshooting fails, see [Getting help](#).

## Troubleshooting iDRAC Direct (laptop connection)

For information about USB laptop connection and server configuration, see the *Integrated Dell Remote Access Controller User's Guide* at [Dell.com/esmanuals](http://Dell.com/esmanuals).

### Steps

1. Ensure your laptop is connected to the front USB Management Port, identified by  icon with a USB Type A/A cable.
2. On the **iDRAC Settings Utility** screen, ensure that the **USB Management Port Mode** is configured as **Automatic** or **iDRAC Direct Only**.
3. If the laptop is running the Windows operating system, ensure the iDRAC Virtual USB NIC device driver is installed.
4. If the driver is installed, ensure you are not connected to any network through WiFi or cabled ethernet as iDRAC Direct uses a non-routable address.

### Next steps

If all troubleshooting fails, see [Getting help](#).

## Troubleshooting a serial I/O device

### Steps

1. Turn off the system and any peripheral devices connected to the serial port.
2. Swap the serial interface cable with a working cable, and turn on the system and the serial device.  
If the problem is resolved, replace the interface cable with a known good cable.
3. Turn off the system and the serial device, and swap the serial device with a comparable device.
4. Turn on the system and the serial device.

### Next steps

If the issue persists, see [Getting Help](#).

## Troubleshooting a NIC

### Steps

1. Run the appropriate diagnostic test. See [Using system diagnostics](#) for available diagnostic tests.
2. Restart the system and check for any system messages pertaining to the NIC controller.
3. Check the appropriate indicator on the NIC connector:
  - If the link indicator does not light, check all cable connections.
  - If the activity indicator does not light, the network driver files might be damaged or missing. Remove and reinstall the drivers if applicable. See the NIC documentation.
  - If applicable, change the autonegotiation setting.
  - Use another connector on the switch or hub.
4. Ensure that the appropriate drivers are installed and the protocols are bound. See the NIC documentation.
5. Enter the System Setup and confirm that the NIC ports are enabled on the **Integrated Devices** screen.
6. Ensure that the NICs, hubs, and switches on the network are all set to the same data transmission speed and duplex. See the documentation for each network device.

7. Ensure that all network cables are of the proper type and do not exceed the maximum length.

#### Next steps

If all troubleshooting fails, see [Getting Help](#).

## Troubleshooting a wet system

#### Prerequisites



**CAUTION:** Many repairs may only be done by a certified service technician. You should only perform troubleshooting and simple repairs as authorized in your product documentation, or as directed by the online or telephone service and support team. Damage due to servicing that is not authorized by Dell is not covered by your warranty. Read and follow the safety instructions that came with the product.

#### Steps

1. Turn off the system and attached peripherals, and disconnect the system from the electrical outlet.
2. Remove the system cover.
3. Remove the following components from the system:
  - hard drives
  - hard-drive backplane
  - USB memory key
  - hard-drive tray
  - cooling shroud
  - expansion-card risers (if present)
  - expansion cards
  - power supply unit(s)
  - cooling-fan assembly (if present)
  - cooling fans
  - processor(s) and heat sink(s)
  - memory modules
4. Let the system dry thoroughly for at least 24 hours.
5. Reinstall the components you removed in step 3.
6. Install the system cover.
7. Turn on the system and attached peripherals.  
If the system does not start properly, see [Getting Help](#).
8. If the system starts properly, shut down the system, and reinstall all the expansion cards that you removed.
9. Run the appropriate diagnostic test. For more information, see [Using system diagnostics](#).

#### Next steps

If the tests fail, see [Getting Help](#).

# Troubleshooting a damaged system

## Prerequisites

 **CAUTION:** Many repairs may only be done by a certified service technician. You should only perform troubleshooting and simple repairs as authorized in your product documentation, or as directed by the online or telephone service and support team. Damage due to servicing that is not authorized by Dell is not covered by your warranty. Read and follow the safety instructions that came with the product.

## Steps

1. Turn off the system and attached peripherals, and disconnect the system from the electrical outlet.
2. Remove the system cover.
3. Ensure that the following components are properly installed:
  - Cooling shroud
  - Expansion-card risers (if present)
  - Expansion cards
  - Power supply(s)
  - Cooling-fan assembly (if present)
  - Cooling fans
  - Processor(s) and heat sink(s)
  - Memory modules
  - Hard-drive carriers
  - Hard-drive backplane
4. Ensure that all cables are properly connected.
5. Install the system cover.
6. Run the appropriate diagnostic test. For more information, see [Using system diagnostics](#).

## Next steps

If the tests fail, see [Getting Help](#).

# Troubleshooting the system battery

## Prerequisites

 **CAUTION:** Many repairs may only be done by a certified service technician. You should only perform troubleshooting and simple repairs as authorized in your product documentation, or as directed by the online or telephone service and support team. Damage due to servicing that is not authorized by Dell is not covered by your warranty. Read and follow the safety instructions that came with the product.

 **NOTE:** If the system is turned off for long periods of time (for weeks or months), the NVRAM may lose its system configuration information. This situation is caused by a defective battery.

 **NOTE:** Some software may cause the system time to speed up or slow down. If the system seems to operate normally except for the time kept in the System Setup, the problem may be caused by software rather than by a defective battery.

### Steps

1. Reenter the time and date in the System Setup.
2. Turn off the system and disconnect it from the electrical outlet for at least one hour.
3. Reconnect the system to the electrical outlet and turn on the system.
4. Go to the System Setup.  
If the date and time are not correct in the System Setup, check the SEL for system battery messages.

### Next steps

If the problem persists, see [Getting Help](#).

## Troubleshooting power supply units

 **CAUTION:** Many repairs may only be done by a certified service technician. You should only perform troubleshooting and simple repairs as authorized in your product documentation, or as directed by the online or telephone service and support team. Damage due to servicing that is not authorized by Dell is not covered by your warranty. Read and follow the safety instructions that came with the product.

### Power source problems

1. Press the power button to ensure that your system is turned on. If the power indicator does not light up when the power button is pressed, press the power-on button firmly.
2. Plug in another working device to ensure that the system board is not faulty.
3. Ensure that no loose connections exist.  
For example, loose power cables.
4. Ensure that the power source meets applicable standards.
5. Ensure that there are no short circuits.
6. Have a qualified electrician check the line voltage to ensure that it meets the required specifications.

### PSU problems

1. Ensure that no loose connections exist.  
For example, loose power cables.
2. Ensure that the PSU handle or LED indicates that the PSU is working properly.
3. If you have recently upgraded your system, ensure that the PSU has enough power to support the new system.
4. If you have a redundant power supply configuration, ensure that both the PSUs are of the same type and wattage.  
You may have to upgrade to a higher wattage PSU.
5. Ensure that you use only PSUs with the Extended Power Performance (EPP) label on the back.
6. Reseat the PSU.

 **NOTE:** After installing a PSU, allow several seconds for the system to recognize the PSU and determine if it is working properly.

If the issue persists, see [Getting Help](#).

## Troubleshooting cooling problems

 **CAUTION:** Many repairs may only be done by a certified service technician. You should only perform troubleshooting and simple repairs as authorized in your product documentation, or as directed by the online or telephone service and support team. Damage due to servicing that is not authorized by Dell is not covered by your warranty. Read and follow the safety instructions that came with the product.

Ensure that the following conditions exist:

- System cover, cooling shroud, EMI filler panel, or back-filler bracket is not removed.
- Ambient temperature is not too high.
- External airflow is not obstructed.
- A cooling fan is not removed or has not failed.
- The expansion card installation guidelines have been followed.

Additional cooling can be added by one of the following methods:

On the iDRAC Web GUI:

1. Click **Hardware** → **Fans** → **Setup**.
2. From the **Fan Speed Offset** drop-down list, select the cooling level needed or set the minimum fan speed to a custom value.

On F2 System Setup:

1. Select **iDRAC Settings** → **Thermal**, and set a higher fan speed from the fan speed offset or minimum fan speed.

From RACADM commands

1. Run the command: `racadm help system.thermalsettings`

For more information, see the *Integrated Dell Remote Access Controller User's Guide* at [Dell.com/idracmanuals](http://Dell.com/idracmanuals).

## Troubleshooting cooling fans

### Prerequisites

 **CAUTION:** Many repairs may only be done by a certified service technician. You should only perform troubleshooting and simple repairs as authorized in your product documentation, or as directed by the online or telephone service and support team. Damage due to servicing that is not authorized by Dell is not covered by your warranty. Read and follow the safety instructions that came with the product.

 **NOTE:** In the event of a problem with a particular fan, the fan number is referenced by the system's management software, allowing you to easily identify and replace the proper fan by noting the fan numbers on the cooling fan assembly.

### Steps

1. Remove the system cover.
2. Reseat the fan or the fan's power cable.

3. Install the system cover.
4. Restart your system.,

#### Next steps

If the problem persists, see [Getting Help](#).

## Troubleshooting system memory

#### Prerequisites



**CAUTION:** Many repairs may only be done by a certified service technician. You should only perform troubleshooting and simple repairs as authorized in your product documentation, or as directed by the online or telephone service and support team. Damage due to servicing that is not authorized by Dell is not covered by your warranty. Read and follow the safety instructions that came with the product.

#### Steps

1. If the system is operational, run the appropriate diagnostic test. See [Using system diagnostics](#) for available diagnostic tests.  
If diagnostics indicate a fault, follow the corrective actions provided by the diagnostic program.
2. If the system is not operational, turn off the system and attached peripherals, and unplug the system from the power source. Wait for at least 10 seconds and then reconnect the system to the power source.
3. Turn on the system and attached peripherals and note the messages on the screen.  
If an error message is displayed indicating a fault with a specific memory module, go to step 12.
4. Open the System Setup page and check the system memory setting. Make any changes to the memory settings, if required.  
If the memory settings match the installed memory but the issue still persists, go to step 12.
5. Turn off the system and attached peripherals, and disconnect the system from the electrical outlet.
6. Remove the system cover.
7. Check the memory channels and ensure that they are populated correctly.  
 **NOTE:** See the system event log or system messages for the location of the failed memory module. Reinstall the memory device.
8. Reseat the memory modules in their sockets.
9. Install the system.
10. Open the System Setup page and check the system memory setting.  
If the issue is not resolved, proceed with the next step.
11. Remove the system cover.
12. If a diagnostic test or error message indicates a specific memory module as faulty, swap or replace the module with a known good memory module.
13. To troubleshoot an unspecified faulty memory module, replace the memory module in the first DIMM socket with a module of the same type and capacity.  
If an error message is displayed on the screen, this may indicate a problem with the installed DIMM type(s), incorrect DIMM installation, or defective DIMM(s). Follow the on-screen instructions to resolve the problem.
14. Install the system cover.
15. As the system boots, observe any error message that is displayed and the diagnostic indicators on the front of the system.

16. If the memory issue persists, repeat step 12 through step 15 for each memory module installed.

#### Next steps

If the issue persists after all memory modules have been checked, see [Getting Help](#).



## Troubleshooting an SD card

### Prerequisites

 **CAUTION:** Many repairs may only be done by a certified service technician. You should only perform troubleshooting and simple repairs as authorized in your product documentation, or as directed by the online or telephone service and support team. Damage due to servicing that is not authorized by Dell is not covered by your warranty. Read and follow the safety instructions that came with the product.

 **NOTE:** Certain SD cards have a physical write-protect switch on the card. If the write-protect switch is turned on, the SD card is not writeable.

### Steps

1. Enter the System Setup and ensure that the **Internal SD Card Port** is enabled.
2. Turn off the system, including any attached peripherals, and disconnect the system from the electrical outlet.
3. Remove the system cover.
  -  **NOTE:** When an SD card failure occurs, the internal dual SD module controller notifies the system. On the next restart, the system displays a message indicating the failure. If redundancy is enabled at the time of SD card failure, a critical alert is logged and chassis health degrades.
4. Replace the failed SD card with a new SD card.
5. Install the system cover.
6. Reconnect the system to its electrical outlet and turn the system on, including any attached peripherals.
7. Enter the System Setup and ensure that the **Internal SD Card Port** and **Internal SD Card Redundancy** mode is set to the required mode.  
Verify that correct SD slot is set as **Primary SD Card**.
8. Check if the SD card is functioning properly.
9. If the **Internal SD Card Redundancy** option is set to **Enabled** at the time of the SD card failure, the system prompts you to perform a rebuild.
  -  **NOTE:** The rebuild is always be sourced from the primary SD card to the secondary SD card. Perform the rebuild of the SD card as necessary.

## Troubleshooting a hard drive

### Prerequisites

 **CAUTION:** Many repairs may only be done by a certified service technician. You should only perform troubleshooting and simple repairs as authorized in your product documentation, or as directed by the online or telephone service and support team. Damage due to servicing that is not authorized by Dell is not covered by your warranty. Read and follow the safety instructions that came with the product.

 **CAUTION:** This troubleshooting procedure can erase data stored on the hard drive. Before you proceed, back up all files on the hard drive.

### Steps

1. Run the appropriate diagnostic test. For more information, see [Using system diagnostics](#). Depending on the results of the diagnostics test, proceed as needed through the following steps.
2. Ensure that the required device drivers for your controller card are installed and are configured correctly. See the operating system documentation for more information.
3. Reboot the system and enter the System Setup.
4. Verify that the controller is enabled and the drives are displayed in the System Setup.

### Next steps

If the problem persists, try troubleshooting the expansion cards or see [Getting Help](#).

## Troubleshooting a storage controller

 **CAUTION:** Many repairs may only be done by a certified service technician. You should only perform troubleshooting and simple repairs as authorized in your product documentation, or as directed by the online or telephone service and support team. Damage due to servicing that is not authorized by Dell is not covered by your warranty. Read and follow the safety instructions that came with the product.

 **NOTE:** When troubleshooting a SAS or PERC controller, see the documentation for your operating system and the controller.

1. Run the appropriate diagnostic test. For more information, see [Using system diagnostics](#).
2. Turn off the system and attached peripherals, and disconnect the system from the electrical outlet.
3. Remove the system cover.
4. Verify that the installed expansion cards are compliant with the expansion card installation guidelines.
5. Ensure that each expansion card is firmly seated in its connector.
6. Install the system cover.
7. Reconnect the system to the electrical outlet, and turn on the system and attached peripherals.
8. If the problem is not resolved, turn off the system and attached peripherals, and disconnect the system from the electrical outlet.
9. Remove the system cover.
10. Remove all expansion cards installed in the system.
11. Install the system cover.
12. Reconnect the system to the electrical outlet, and turn on the system and attached peripherals.
13. Run the appropriate diagnostic test. For more information, see . If the tests fail, see [Getting Help](#).
14. For each expansion card you removed in step 10, perform the following steps:
  - a. Turn off the system and attached peripherals, and disconnect the system from the electrical outlet.
  - b. Remove the system cover.
  - c. Reinstall one of the expansion cards.
  - d. Install the system cover.
  - e. Run the appropriate diagnostic test. For more information, see [Using system diagnostics](#).

If the tests fail, see [Getting Help](#).

# Troubleshooting expansion cards

## Prerequisites

 **CAUTION:** Many repairs may only be done by a certified service technician. You should only perform troubleshooting and simple repairs as authorized in your product documentation, or as directed by the online or telephone service and support team. Damage due to servicing that is not authorized by Dell is not covered by your warranty. Read and follow the safety instructions that came with the product.

 **NOTE:** When troubleshooting an expansion card, see the documentation for your operating system and the expansion card.

## Steps

1. Run the appropriate diagnostic test. For more information, see [Using system diagnostics](#).
2. Turn off the system and attached peripherals, and disconnect the system from the electrical outlet.
3. Remove the system cover.
4. Ensure that each expansion card is firmly seated in its connector.
5. Install the system cover.
6. If the problem is not resolved, turn off the system and attached peripherals, and disconnect the system from the electrical outlet.
7. Remove the system cover.
8. Remove all expansion cards installed in the system.
9. Install the system cover.  
If the tests fail, see [Getting Help](#).
10. For each expansion card you removed in step 8, perform the following steps:
  - a. Turn off the system and attached peripherals, and disconnect the system from the electrical outlet.
  - b. Remove the system cover.
  - c. Reinstall one of the expansion cards.
  - d. Install the system cover.
  - e. Run the appropriate diagnostic test. For more information, see [Using system diagnostics](#).

## Next steps

If the problem persists, see [Getting Help](#).

# Troubleshooting processors

## Prerequisites

 **CAUTION:** Many repairs may only be done by a certified service technician. You should only perform troubleshooting and simple repairs as authorized in your product documentation, or as directed by the online or telephone service and support team. Damage due to servicing that is not authorized by Dell is not covered by your warranty. Read and follow the safety instructions that came with the product.

## Steps

1. Run the appropriate diagnostics test. See [Using system diagnostics](#) for available diagnostic tests.
2. Turn off the system and attached peripherals, and disconnect the system from the electrical outlet.
3. Remove the system cover.

4. Ensure that the processor and heat sink are properly installed.
5. Install the system cover.
6. Run the appropriate diagnostic test. For more information, see [Using system diagnostics](#).

#### Next steps

If the problem persists, see [Getting Help](#).

## System messages

For a list of event and error messages generated by the system firmware and agents that monitor system components, see the Dell Event and Error Messages Reference Guide at [Dell.com/idracmanuals](http://Dell.com/idracmanuals).

### Warning messages

A warning message alerts you to a possible problem and prompts you to respond before the system continues a task. For example, before you format a hard drive, a message warns you that you may lose all data on the hard drive. Warning messages usually interrupt the task and require you to respond by typing y (yes) or n (no).

 **NOTE:** Warning messages are generated by either the application or the operating system. For more information, see the documentation that accompanied the operating system or application.

### Diagnostic messages

The system diagnostic utilities may issue messages if you run diagnostic tests on your system. See [Using system diagnostics](#) for more information about system diagnostics.

### Alert messages

The systems management software generates alert messages for your system. Alert messages include information, status, warning, and failure messages for drive, temperature, fan, and power conditions. For more information, see the systems management software documentation.

## Using system diagnostics

If you experience a problem with your system, run the system diagnostics before contacting Dell for technical assistance. The purpose of running system diagnostics is to test your system hardware without requiring additional equipment or risking data loss. If you are unable to fix the problem yourself, service and support personnel can use the diagnostics results to help you solve the problem.

### Dell Embedded System Diagnostics

 **NOTE:** The Dell Embedded System Diagnostics is also known as Enhanced Pre-boot System Assessment (ePSA) diagnostics.

The embedded system diagnostics provides a set of options for particular device groups or devices allowing you to:

- Run tests automatically or in an interactive mode
- Repeat tests
- Display or save test results
- Run thorough tests to introduce additional test options to provide extra information about the failed device(s)
- View status messages that inform you if tests are completed successfully
- View error messages that inform you of problems encountered during testing

### When to use the Embedded System Diagnostics

If a major component or device in the system does not operate properly, running the embedded system diagnostics may indicate component failure.

### Running the Embedded System Diagnostics from Boot Manager

1. As the system boots, press **F11**.
2. Use the up-and down arrow keys to select **System Utilities** → **Launch Diagnostics**.  
The **ePSA Pre-boot System Assessment** window is displayed, listing all devices detected in the system. The diagnostics starts running the tests on all the detected devices.

### Running the Embedded System Diagnostics from the Dell Lifecycle Controller

1. As the system boots, press **F11**.
2. Select **Hardware Diagnostics** → **Run Hardware Diagnostics**.  
The **ePSA Pre-boot System Assessment** window is displayed, listing all devices detected in the system. The diagnostics starts running the tests on all the detected devices.

## System diagnostic controls





Menu	Description
<b>Configuration</b>	Displays the configuration and status information of all detected devices.
<b>Results</b>	Displays the results of all tests that are run.
<b>System health</b>	Provides the current overview of the system performance.
<b>Event log</b>	Displays a time-stamped log of the results of all tests run on the system. This is displayed if at least one event description is recorded.

For information about embedded system diagnostics, see the *ePSA Diagnostics Guide (Notebooks, Desktops and Servers)* available at [Dell.com/support/home](http://Dell.com/support/home).

# Jumpers and connectors

## System board jumper settings

Table 29. System board jumper settings

Jumper	Setting	Description
PWRD_EN	 2 4 6 (default)	The password reset feature is enabled (pins 2–4). BIOS local access is unlocked at the next AC power cycle.
	 2 4 6	The password reset feature is disabled (pins 4–6).
NVRAM_CLR	 1 3 5 (default)	The configuration settings are retained at the next system boot (pins 3–5).
	 1 3 5	The configuration settings are cleared at system boot (pins 1–3).

## System board connectors

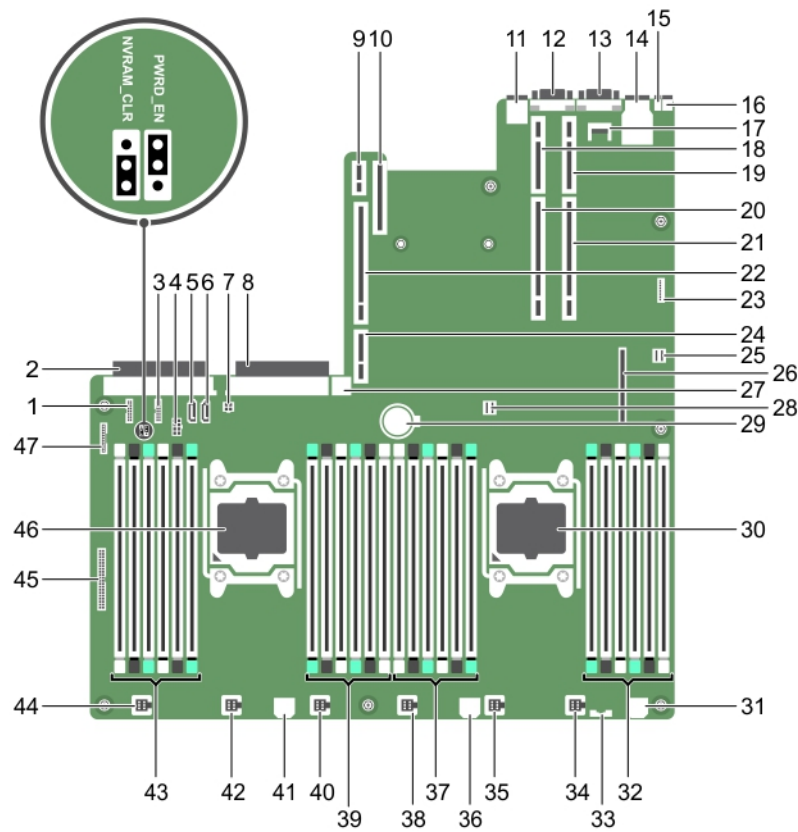

Figure 53. System board jumpers and connectors

Table 30. System board jumpers and connectors

Item	Connector	Description
1	J_BP_SIG1	Backplane signal connector 1
2	J_PS_2	PSU 2 connector
3	J_BP_SIG0	Backplane signal connector 0
4	J_BP0	Backplane power connector 0
5	J_SATA_CD	Optical drive SATA connector, SATADOM connector
6	J_SATA_TBU	Tape backup unit SATA connector
7	J_TBU	SATADOM power connector
8	J_PS_1	PSU 1 connector
9	J_IDSDM	Internal dual SD module connector

<b>Item</b>	<b>Connector</b>	<b>Description</b>
10	J_NDC	Network daughter card connector
11	J_USB	USB connector
12	J_VIDEO_REAR	Video connector
13	J_COM1	Serial connector
14	J_IDRAC_RJ45	iDRAC8 connector
15	J_CYC	System identification connector
16	CYC_ID	System identification button
17	J_TPM_MODULE	Trusted Platform Module connector
18	J_RISER_2AX	Riser 3 connector
19	J_RISER_1AX	Riser 1 connector
20	J_RISER_2BX	Riser 2 connector
21	J_RISER_1BX	Riser 1 connector
22	J_RISER_3AX	Riser 3 connector
23	J_QS	Quick Sync bezel connector
24	J_RISER_3BX	Riser 3 connector
25	J_SATA_B	Internal SAS connector
26	J_STORAGE	Mini PERC connector
27	J_USB_INT	Internal USB connector
28	J_SATA_A	Internal SAS connector
29	BAT	Battery connector
30	CPU 2	Processor socket 2
31	J_BP3	Backplane power connector 3
32	B10, B6, B2, B9, B5, B1	Memory module sockets
33	J_BP_SIG2	Backplane signal connector 2
34	J_FAN2U_6	Cooling fan connector
35	J_FAN2U_5	Cooling fan connector
36	J_BP2	Backplane power connector 2
37	B3, B7, B11, B4, B8, B12	Memory module sockets
38	J_FAN2U_4	Cooling fan connector
39	A10, A6, A2, A9, A5, A1	Memory module sockets
40	J_FAN2U_3	Cooling fan connector
41	J_BP1	Backplane power connector
42	J_FAN2U_2	Cooling fan connector

Item	Connector	Description
43	A3, A7, A11, A4, A8, A12	Memory module sockets
44	J_FAN2U_1	Cooling fan connector
45	J_CTRL_PNL	Control panel signal connector
46	CPU 1	Processor 1
47	J_FP_USB	Front-panel USB connector

## Disabling a forgotten password

The system's software security features include a system password and a setup password. The password jumper enables these password features or disables them and clears any password(s) currently in use.

### Prerequisites

 **CAUTION:** Many repairs may only be done by a certified service technician. You should only perform troubleshooting and simple repairs as authorized in your product documentation, or as directed by the online or telephone service and support team. Damage due to servicing that is not authorized by Dell is not covered by your warranty. Read and follow the safety instructions that came with the product.

### Steps

1. Turn off the system, including any attached peripherals, and disconnect the system from the electrical outlet.
2. Open the system.
3. Move the jumper on the system-board jumper from pins 4 and 6 to pins 2 and 4.
4. Close the system.

The existing passwords are not disabled (erased) until the system boots with the jumper on pins 2 and 4. However, before you assign a new system and/or setup password, you must move the jumper back to pins 4 and 6.

 **NOTE:** If you assign a new system and/or setup password with the jumper on pins 2 and 4, the system disables the new password(s) the next time it boots.

5. Reconnect the system to its electrical outlet and turn the system on, including any attached peripherals.
6. Turn off the system, including any attached peripherals, and disconnect the system from the electrical outlet.
7. Open the system.
8. Move the jumper on the system-board jumper from pins 2 and 4 to pins 4 and 6.
9. Close the system.
10. Reconnect the system to its electrical outlet and turn the system on, including any attached peripherals.
11. Assign a new system and/or setup password.

# Getting help

## Contacting Dell

Dell provides several online and telephone-based support and service options. If you do not have an active internet connection, you can find contact information on your purchase invoice, packing slip, bill, or Dell product catalog. Availability varies by country and product, and some services may not be available in your area. To contact Dell for sales, technical assistance, or customer-service issues:

1. Go to **Dell.com/support**.
2. Select your country from the drop-down menu on the bottom right corner of the page.
3. For customized support:
  - a. Enter your system Service Tag in the **Enter your Service Tag** field.
  - b. Click **Submit**.  
The support page that lists the various support categories is displayed.
4. For general support:
  - a. Select your product category.
  - b. Select your product segment.
  - c. Select your product.  
The support page that lists the various support categories is displayed.
5. For contact details of Dell Global Technical Support:
  - a. Click [Global Technical Support](#).
  - b. The **Technical Support** page is displayed with details to call, chat, or e-mail the Dell Global Technical Support team.

## Dell SupportAssist

For an enhanced Support Experience, Dell recommends installing and configuring Dell SupportAssist.

Dell SupportAssist is a software application that transparently collects information about your system and automatically creates support cases when issues are detected. Dell SupportAssist helps Dell to provide you an enhanced, personalized, and efficient support experience. Dell uses the data to solve common problem, designs and markets the products.

For more information about installing and configuring Dell SupportAssist, see: <http://www.dell.com/en-us/work/learn/supportassist-servers-storage-networking>.

## Locating Service Tag of your system

Your system is identified by a unique Express Service Code and Service Tag number. The Express Service Code and Service Tag are found on the front of the system by pulling out the information tag.

Alternatively, the information may be on a sticker on the chassis of the system. This information is used by Dell to route support calls to the appropriate personnel.

## Quick Resource Locator

Use the Quick Resource Locator (QRL) to get immediate access to system information and how-to videos. This can be done by visiting [Dell.com/QRL](http://Dell.com/QRL) or by using your smartphone or tablet and a model specific Quick Resource (QR) code located on your Dell system. To try out the QR code, scan the following image.



Figure 54. Quick Resource Locator